

NO.	DATE	REVISION / REMARKS
1	JUL 2019	GENERAL REVISION
2	JAN 2023	GENERAL REVISION

STD DETAILS  
SHEET NUMBER  
0 OF 0

SEAL

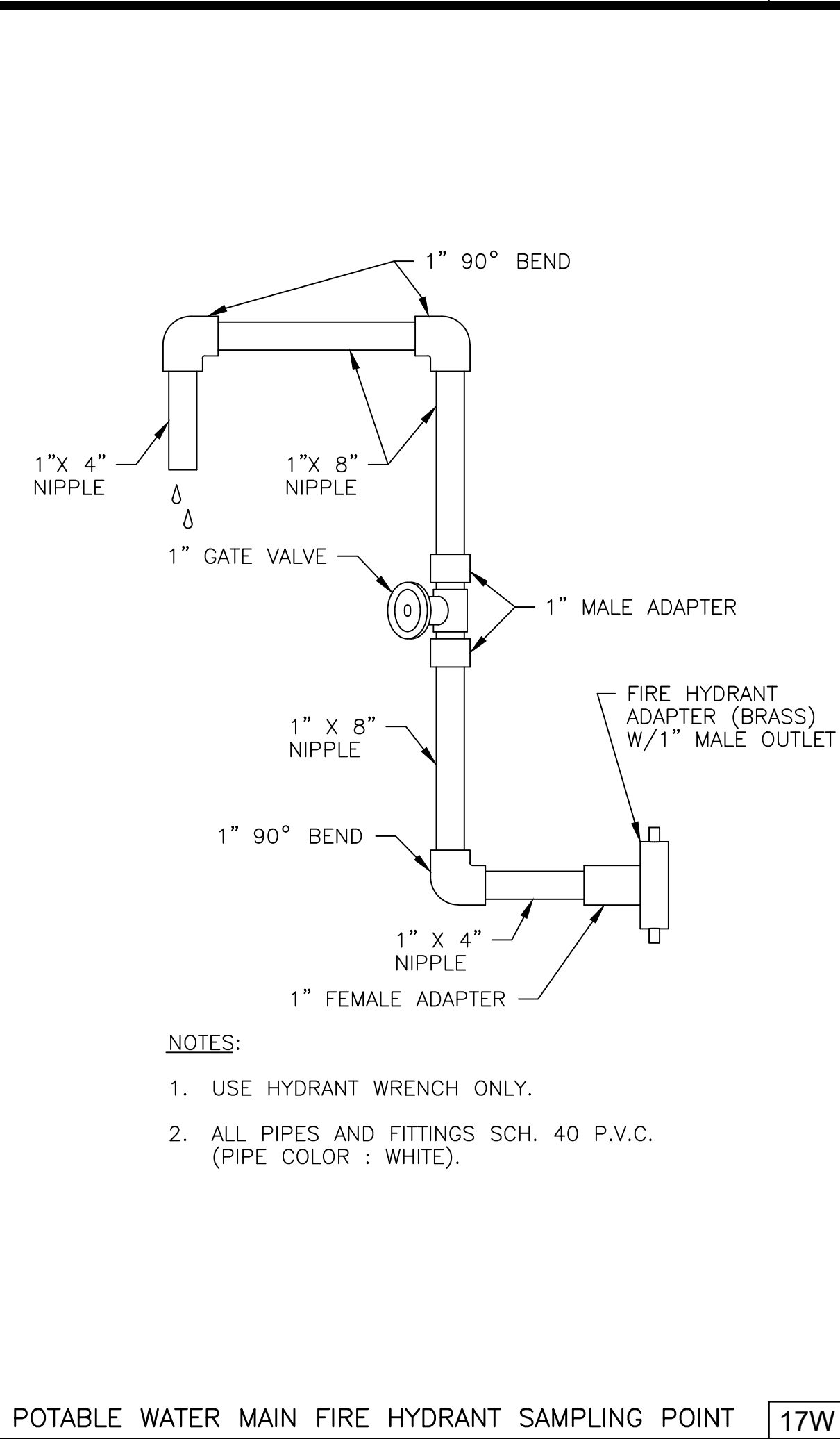
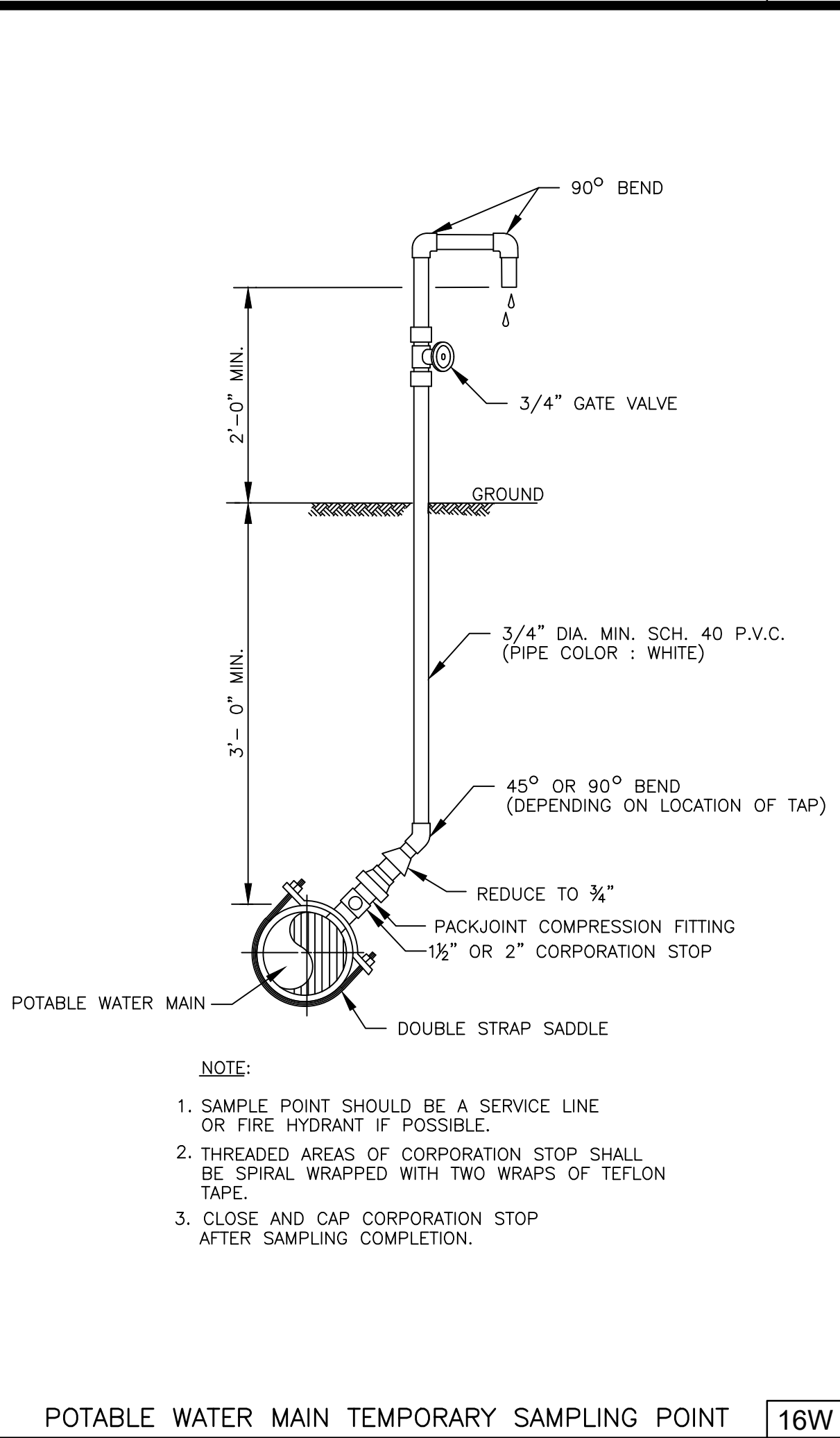
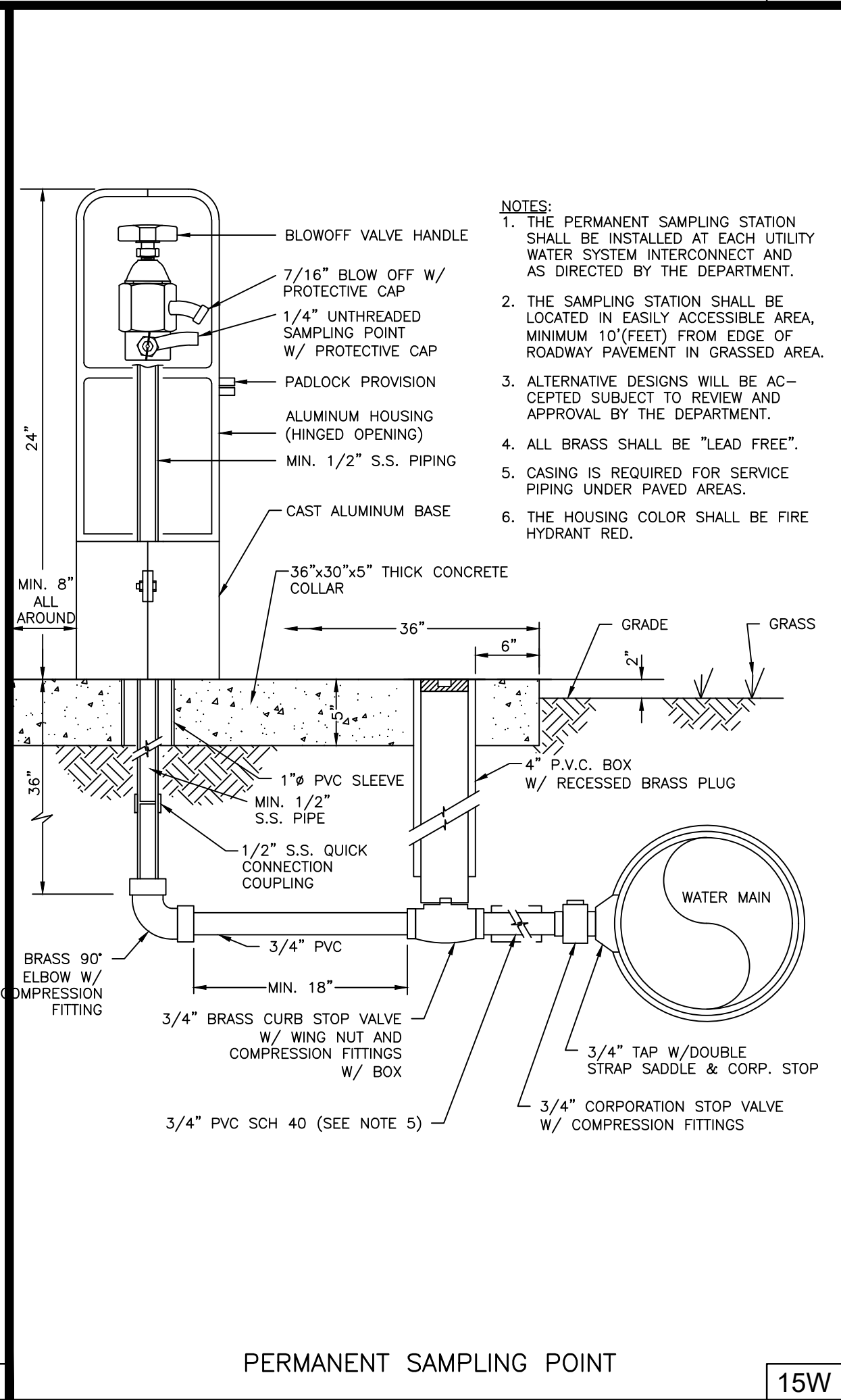
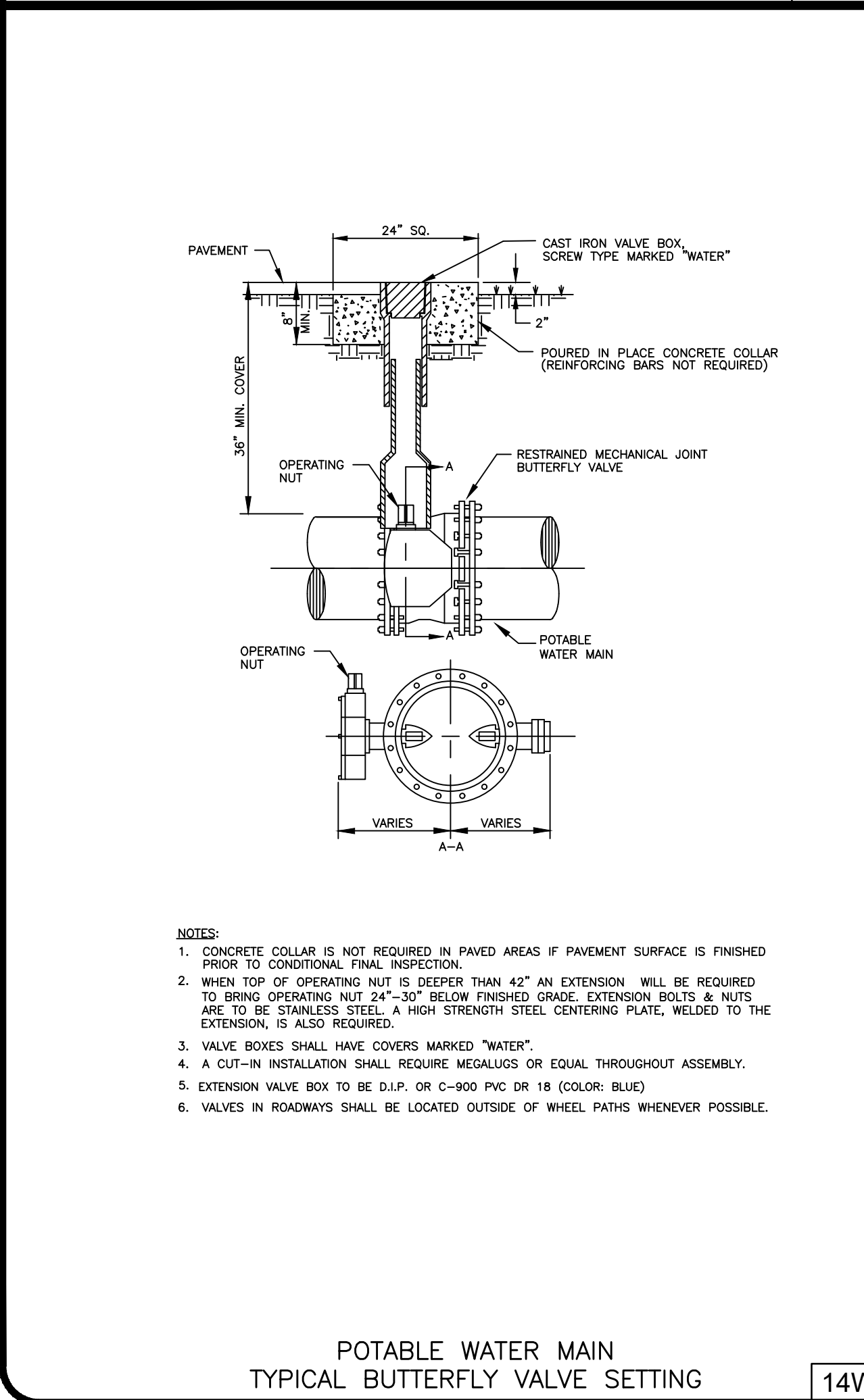
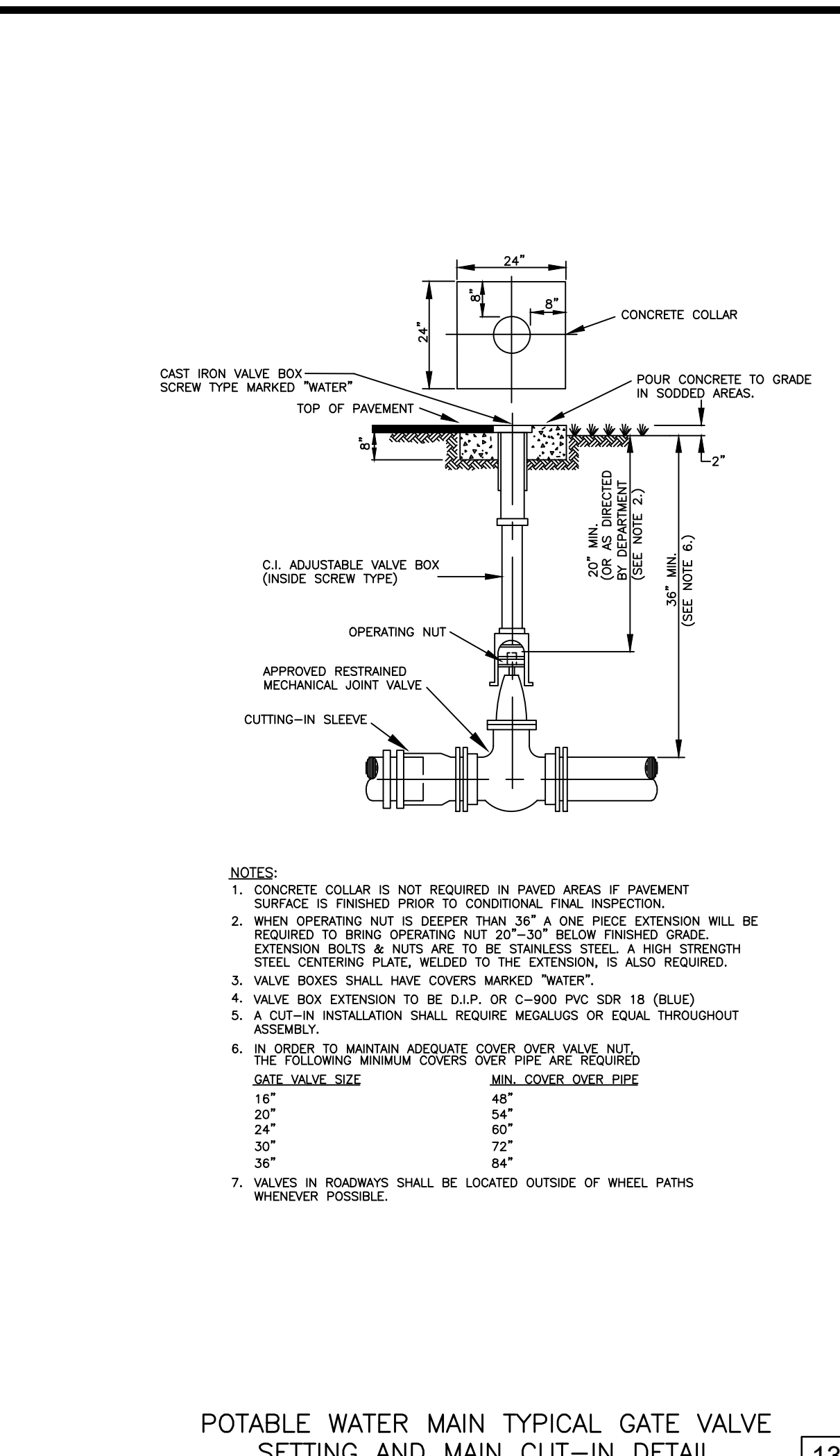
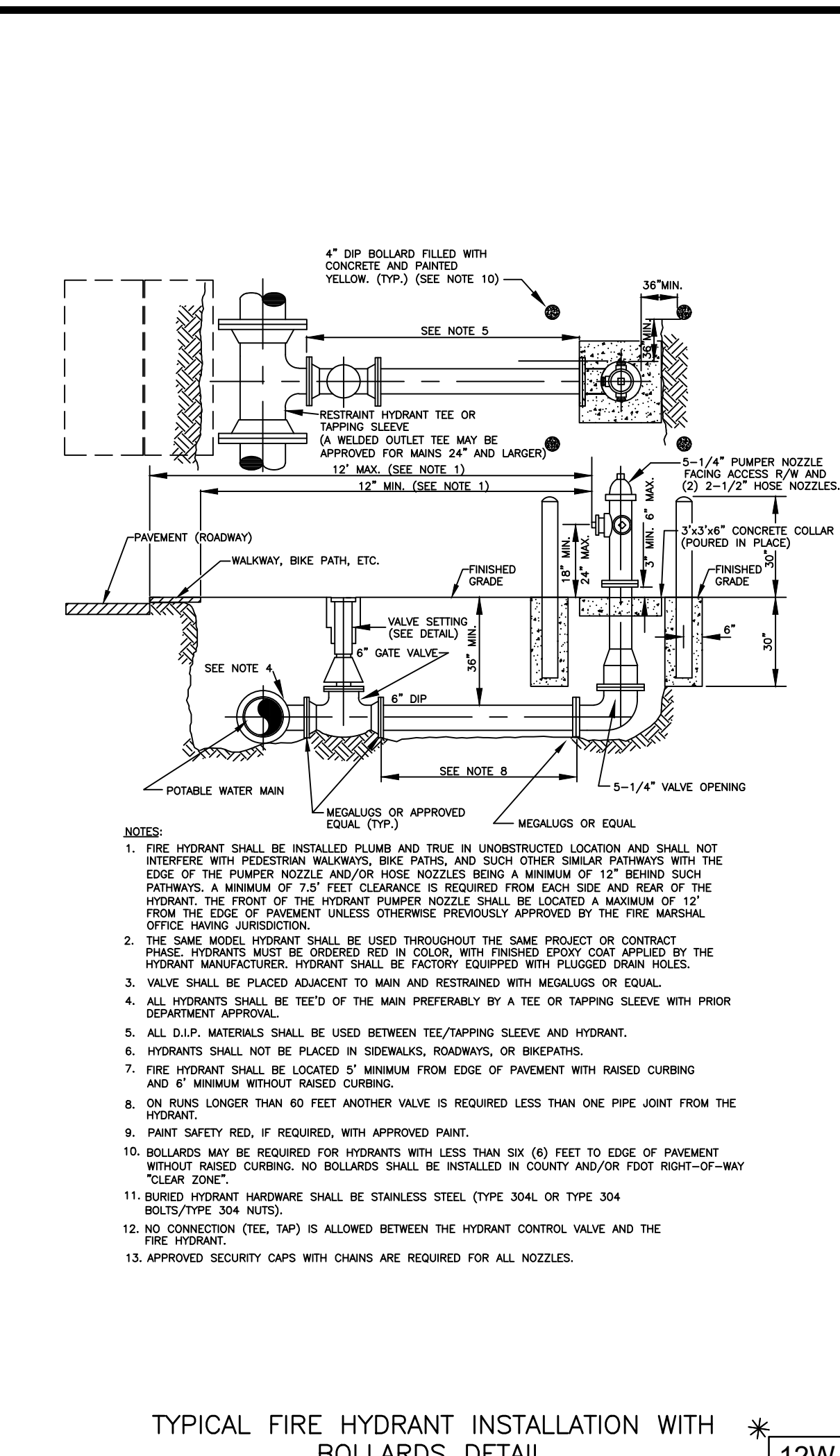
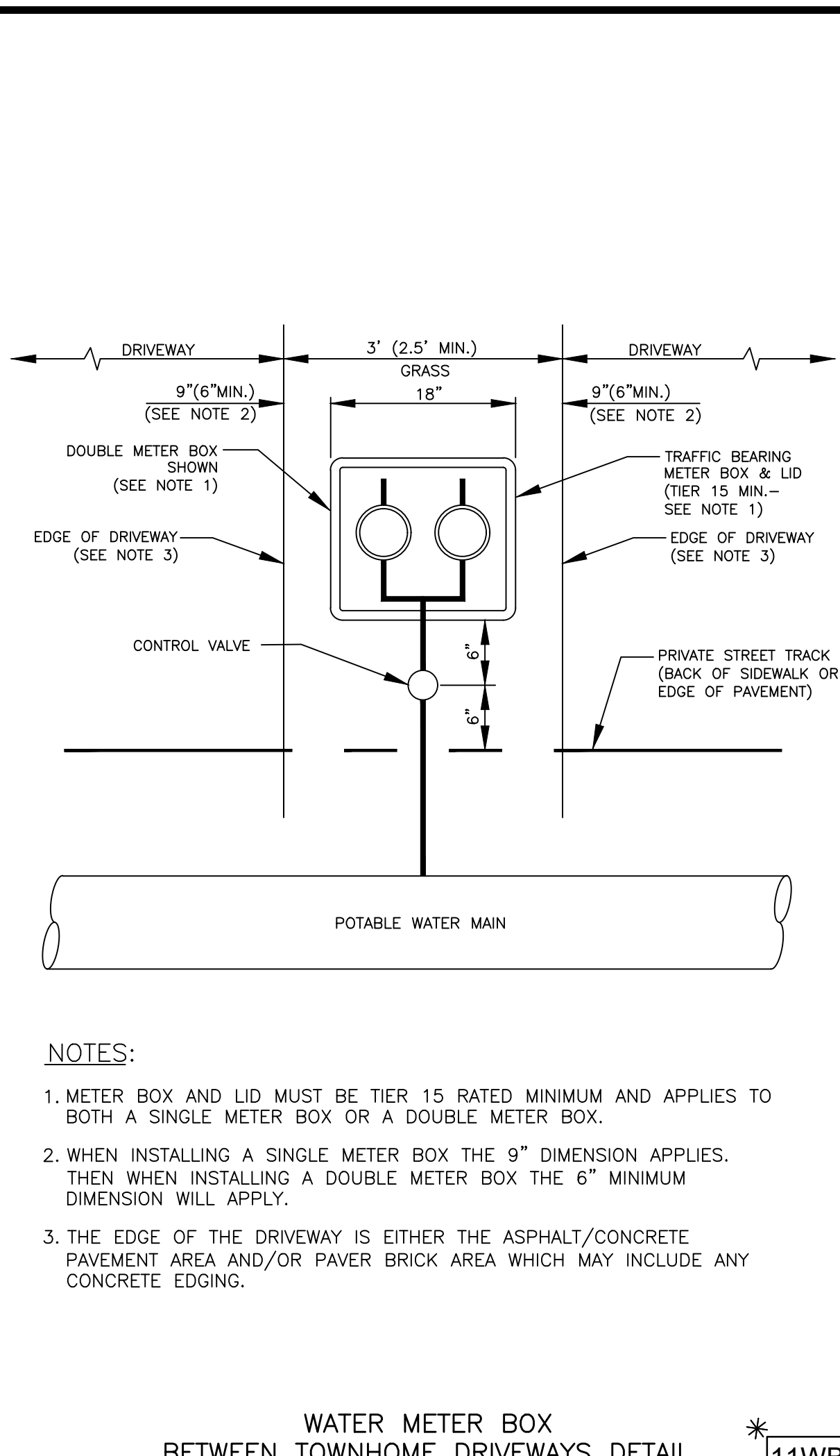
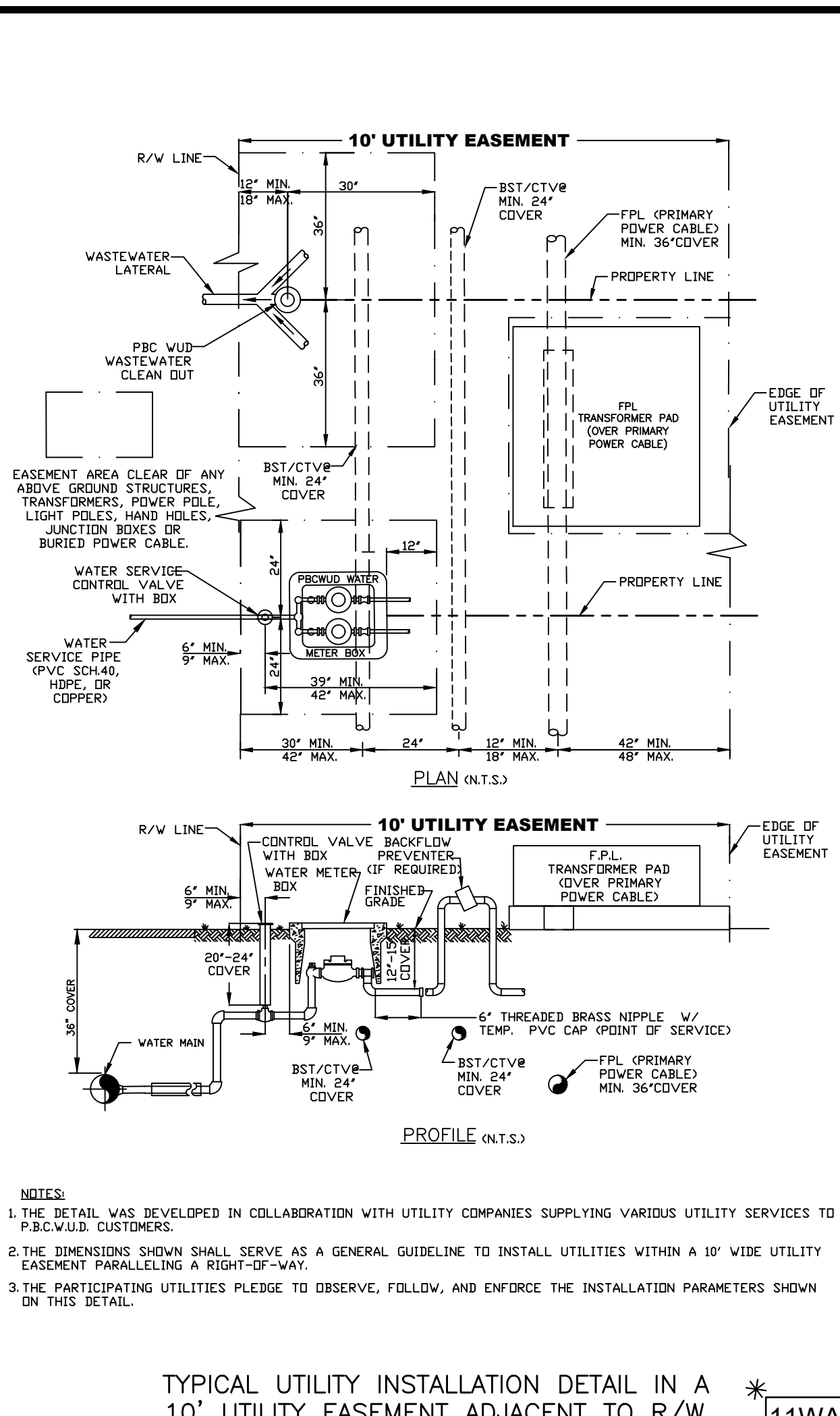
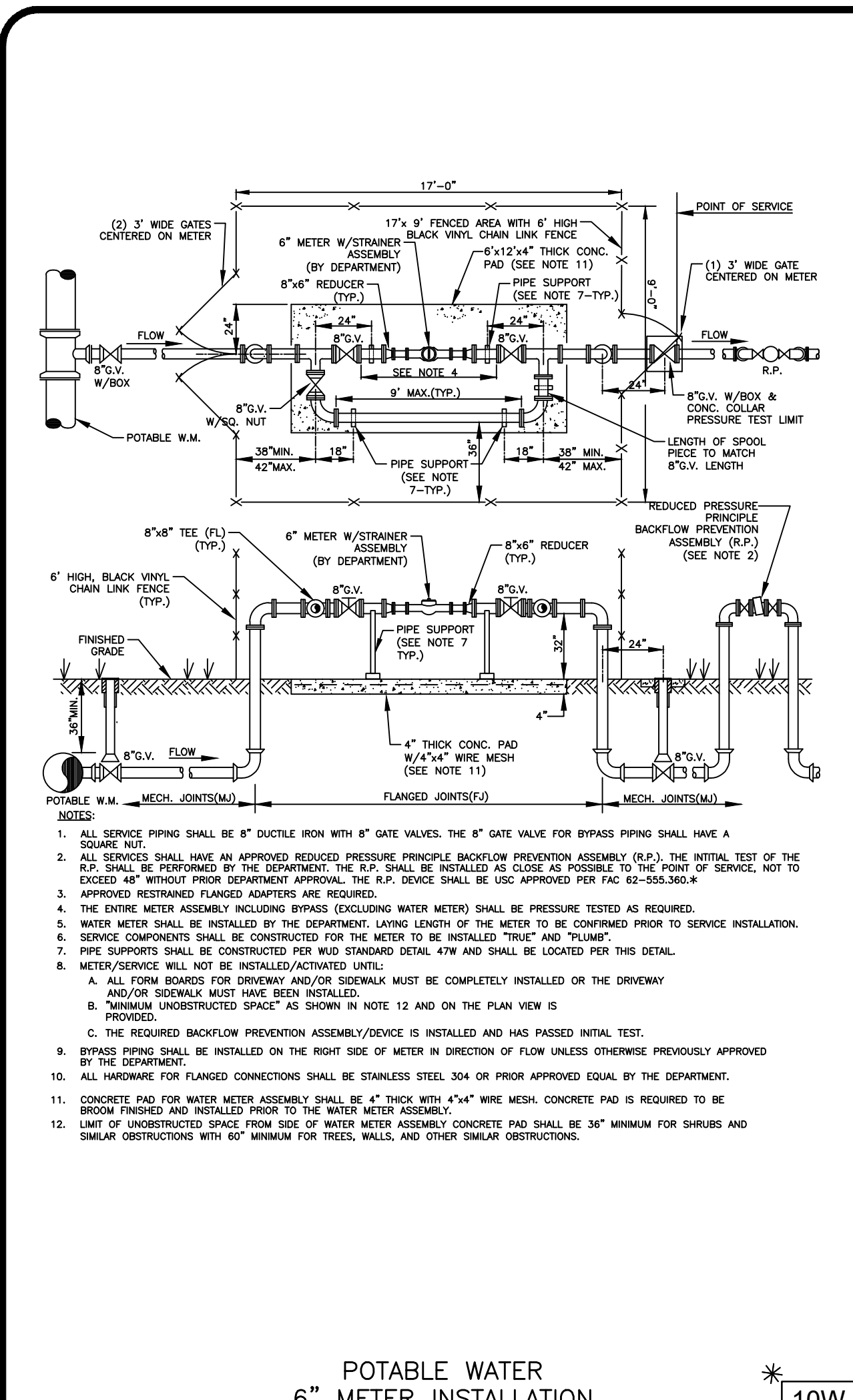

**THIS SPACE INTENTIONALLY LEFT BLANK**

**POTABLE WATER #2 STANDARD DETAILS**

**CONSULTANT:**

**IT'S THE LAW!**  
CALL 48 HOURS BEFORE YOU DIG  
**1-800-432-4770**  
SUNSHINE STATE ONE CALL OF FLORIDA, INC.  
UTILITIES NOTIFICATION CENTER

DESIGNED BY: WUD

DRAWN BY: M. BUCKNER Palm Beach County  
CHECKED BY: J. LAMMERT Water Utilities Department  
APPROVED BY: WUD P.O. Box 16097  
West Palm Beach, FL 33416-6097

Mar 01, 2023