

**RESIDENTIAL GENERATOR PERMITTING CHECKLIST**  
**ART.702 N.E.C. 2005 EDITION (ART. 220 and 445)**

ALL SUB PERMIT REQUESTS SHOULD BE SUBMITTED AT THE TIME OF INITIAL APPLICATION, AND  
TWO SETS ARE REQUIRED OF EVERYTHING LISTED BELOW  
**PERMITS NEEDED: ELECTRICAL AND MECHANICAL (GAS)**

**SITE SURVEY DRAWING: SURVEY DRAWING "MUST" HAVE FLOOD ZONE INFO ON IT.** Show generator and fuel tank locations with fuel lines. Show location of all windows and doors near the generator exhaust, **GENERATOR EXHAUST SHALL BE 10 ft. AWAY FROM OPERABLE WINDOWS and DOORS, INCLUDING THOSE IN THE NEIGHBORS HOUSE. (EXCULDING GARAGE WINDOWS AND DOORS) THE GENERATOR EXHAUST MAY NOT DISCHARGE ON TO THE ADJACENT PROPERTY. PER FBC MECHANICAL CODE SECTION 401.5.51**

**Flood Zone:** Must comply with **Flood Damage Prevention Ordinance No. 2004-013 & PPM #: PBO-119**  
**Any flood zone not "B or C" must be at or above the finished floor elevation.** Specify Flood Zone; and, identify the main building FFE if anything other than B, C.

**SLAB DRAWING:** Show slab size, depth of slab and type of reinforcement used. Specify generator anchor details. Generator must be set as close to the building as allowable by code and spacing from the building **SHALL MEET** manufacturer's specifications.

**RISER DRAWING** Provide a complete electrical riser drawing including service size, panel(s), transfer switch, main disconnect(s) and generator installation. Show all wire, conduit, breaker sizes and equipment sizes/ratings

**LOAD CALCULATION** (To determine the size of the generator and transfer switch): A **whole house** generator system will be calculated with the optional method N.E.C. 220. Separate **EM" panel(s)** will be calculated at 100% of their load, Or by demand meter with approval of Chief Electrical Inspector per NEC 220.87 (1) exception (must provide information).

**GENERATOR SPECS.** Provide generator specifications for the generator including **KW rating, output amps, size of generator breaker, type of fuel being used and the sound rating.**

**TRANSFER SWITCH:** Required for all generators per N.E.C. 702.6 (specify rating).

**MANUAL TRANSFER SWITCH: (OPTIONS)**

- A. Size for the entire load of the service, or
- B. Size for dedicated optional standby NEC 702 panel(s), which may be built into the panel as a transfer switch with mechanical interlock, or a separate transfer switch. All loads to service must be identified. If cord connected, the receptacle shall be sized for at least the corresponding over current protection at the generator, or other over current protection device in front of the receptacle, not to exceed the output capacity of the generator.

**AUTOMATIC TRANSFER SWITCH:(OPTIONS)**

- A. Sized to transfer the entire load **whole house, load calculation per NEC 220**
- B. Pre-select **"EM" panel(s)** the load to be served with an existing panel or optional standby panel and transfer switch. **Loads at 100%**
- C. Provide automatic load shedding to reduce total load imposed on the generator, not to exceed output capacity of the generator.

**SCREENING:** Provide an **OPAQUE** screen around unit to screen the generator from the street and adjacent property views. The property owner can install or utilize an existing 4 ft. opaque fence or wall or hedges around the unit. A shadowbox fence is **NOT** an opaque screen.

**SOUND LIMITS:** The decibel level shall not exceed the 75db level at the nearest property line, as established by section 5.E.3.C1 of the Palm Beach County Unified Land Development Code.

**AFFIDAVIT:** Before a certificate of completion is issued a **Generator Noise-Limit Compliance Affidavit** attesting to the results of a sound measurement at the property line, must be filled out, signed and left with the permit for the inspector to pickup.

**SIGN:** A sign shall be placed at the service-entrance equipment that indicates the location of on-site optional standby power sources. Per N.E.C. 702.8

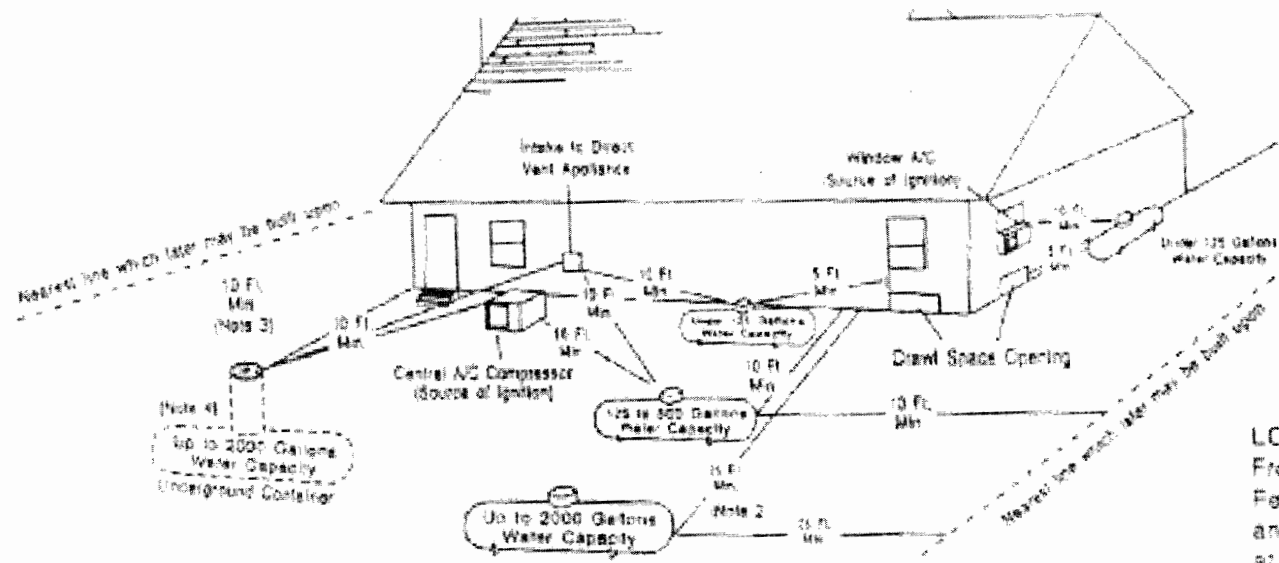

**LOCATION OF ASME CONTAINERS**  
 From NFPA 58, Appendix G  
 Federal, state, or local ordinances  
 and regulations should be observed  
 at all times.

les.

Regardless of its size, any ASME tank filled on-site must be located so that the filling connection and fixed liquid level gauge are at least 10 feet from external source of ignition (i.e. open flame, window A/C, compressor, etc.), intake to direct vented gas appliance or intake to a mechanical ventilation system.

May be reduced to 10 feet minimum for a single container of 1200 gallons water capacity or less if it is located at least 25 feet from any other LP Gas container of more than 125 gallons water capacity.

Minimum distances from underground containers shall be measured from the relief valve and filling or level gauge vent connection at the container, except that no part of an underground container shall be less than 10 feet from a building or line of adjoining property which may be built upon.

Where the container may be subject to abrasive action or physical damage due to vehicular traffic or other causes it must be either: (a) placed not less than 2 feet below grade; (b) otherwise protected against such physical damage.

This information was compiled using accepted industry data. AWT is not responsible for its use or interpretation.

**NOTE: TANK AND LINES CAN NOT ENCROACH INTO EASEMENTS PER ULDC, SECTION 6.5 K**

**COMMERCIAL GENERATOR PERMITTING CHECKLIST**  
**ART.700 and 702 N.E.C. 2005 EDITION (ART. 220 and 445)**

**PERMITS NEEDED ELECTRICAL AND MECHANICAL (GAS)**

**SITE SURVEY DRAWING: May need a DRC administrative amendment.**

Show generator and fuel tank locations with fuel lines. Show location of all windows and doors near the generator exhaust **GENERATOR EXHAUST SHALL BE 10 ft. WINDOW and DOORS, THE GENERATOR EXHAUST MAY NOT DISCHARGE ON TO THE ADJACENT PROPERTY.**

**Flood Zone:** Must comply with **Flood Damage Prevention Ordinance No. 2004-013 & PPM #: PBO-119 Any flood zone not "B or C" must be at or above the finished floor elevation.** Specify Flood Zone; and, identify the main building FFE if anything other than B or C.

**SLAB DRAWING:** Show slab size, depth of slab and type of reinforcement used. Specify generator anchor details. Generator must be set as close to the building as allowable by code and spacing from the building **SHALL MEET** manufacturer's specifications.

**RISER DRAWING** Provide an electrical riser drawing. Complete with service, panel(s), transfer switch, main disconnect(s) and generator installation. Show breaker, pipe and wire sizes.

**LOAD CALCULATION** (To determine the size of the generator and transfer switch): A whole building generator system will be **Sized per NEC 220 service calculation or FPL demand meter reading for the past 12 months. Separate "EM" panel(s) will be calculated at 100% of the load.**

**GENERATOR SPECS.** Provide generator specifications including the kW rating, output amps, size of generator breaker, type of fuel being used and the sound rating.

**TRANSFER SWITCH:** Required for all generators per N.E.C. 702.6. Provide transfer specification on the transfer switch.

**MANUAL TRANSFER SWITCH: (OPTIONS)**

- A. Sized for the entire load on the service, or
- B. Sized for dedicated optional standby NEC 702 panel(s), which may be built into the panel as a transfer switch with mechanical interlock, or a separate transfer switch. All loads to service must be identified. If cord connected, the receptacle or cam-locks shall be sized for at least the corresponding over current protection at the generator, or other over current protection device in front of the receptacle, not to exceed the output capacity of the generator.

**AUTOMATIC TRANSFER SWITCH:(OPTIONS)**

- A. Sized to transfer the entire load. **Sized per NEC service calculation or FLP demand meter reading for the past 12 months.**
- B. Pre-select ("EM" panel(s)) the load to be served with an optional standby panel and transfer switch. **Loads calculated at 100%**
- C. Provide automatic load shedding to reduce total load imposed on the generator, not to exceed output capacity of the generator.

**SCREENING:** Provide an **OPAQUE** screen around unit to screen the generator from the street and Adjacent property views. The screening must be to the **top of equipment**, by the use of opaque fence or wall or hedges around the unit. A shadowbox fence is **NOT** an opaque screen. Maintain clearances required by NEC and manufacturer specs

**SOUND LIMITS:** The decibel level shall not exceed the 75db level at the nearest property line, as established by section 5.E.3.C1 of the Palm Beach County Unified Land Development Code.

**AFFIDAVIT:** Before a certificate of completion is issued a **Generator Noise-Limit Compliance Affidavit** attesting to the results of a sound measurement at the property line. Must be filled out, signed and left with the permit for the inspector to pickup.

**SIGN:** A sign shall be placed at the service- entrance equipment that indicates the location of on-site optional standby power sources. Per N.E.C. 702.8



# DEDICATED SYSTEM W/ MANUAL TRANSFER RESIDENTIAL ONLY (N.E.C.2002 SEC. 702)

**INFORMATIONAL ONLY NOT FOR PERMITTING**

**NOTE:** Applicant must fill in all clouded areas, check all applicable boxes and open fields for permit submittal

**SCREENING TYPE:**

EXISTING FENCE

WOOD FENCE

CBS WALL

HEDGES

**SOUND AFFIDAVIT**  
FILLED OUT & SIGNED AT TIME OF INSPECTION TO GET A CERTIFICATE OF COMPLETION

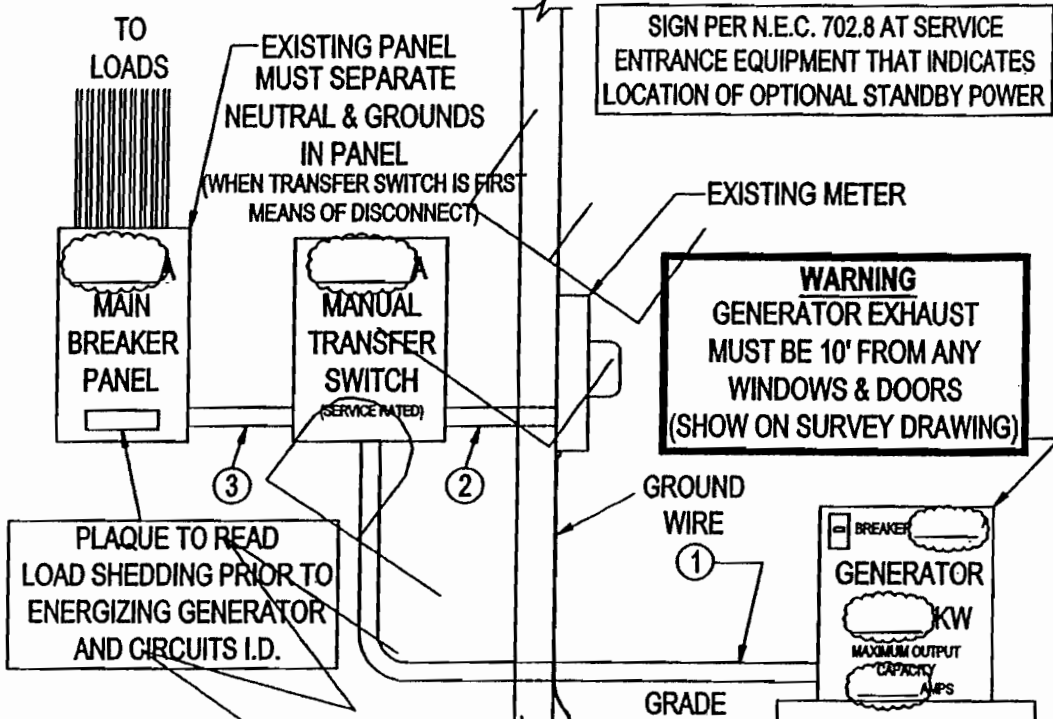

## SLAB & FUEL INFORMATION

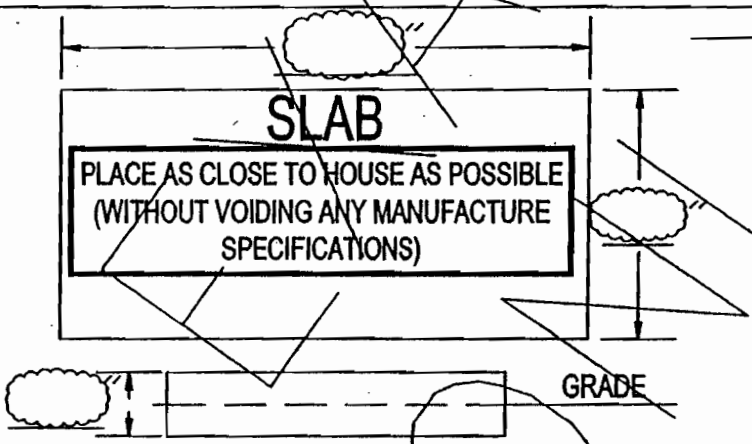

CHECK  REINFORCEMENT STEEL OR MESH

ONE  FIBER CRETE  LT. WT. SLAB

SLAB & TIE DOWN

### WIRE & PIPE SIZE W/ BOND

① \_\_\_\_\_

② \_\_\_\_\_

③ \_\_\_\_\_

### TIE DOWN INFO

TYPE & BOLT SIZE \_\_\_\_\_

HOW MANY \_\_\_\_\_

**FUEL** CHECK ONE

LP  NATURAL

OTHER \_\_\_\_\_



# WHOLE HOUSE W/ AUTOMATIC TRANSFER RESIDENTIAL ONLY (N.E.C. 2002 SEC. 702)

**INFORMATIONAL ONLY NOT FOR PERMITTING**

**NOTE:** Applicant must fill in all clouded areas, check all applicable boxes and open fields for permit submittal

**SCREENING TYPE:**

EXISTING FENCE

WOOD FENCE

CBS WALL

HEDGES

**SOUND AFFIDAVIT**  
FILLED OUT & SIGNED AT TIME OF INSPECTION TO GET A CERTIFICATE OF COMPLETION

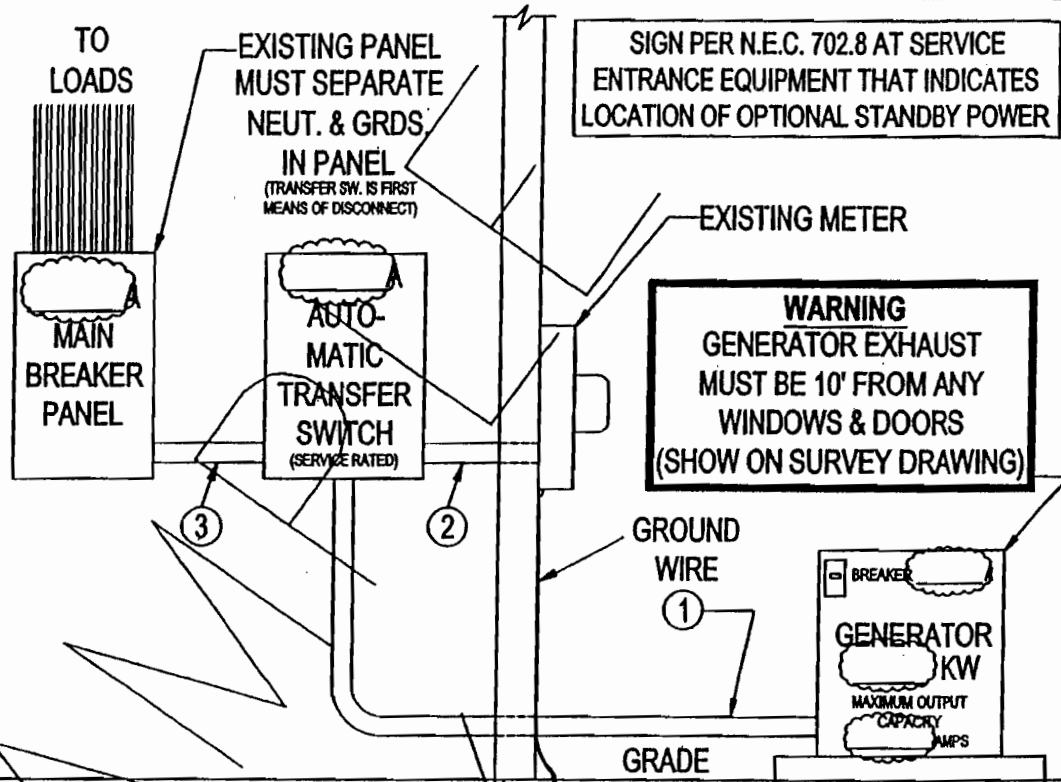

## SLAB & FUEL INFORMATION

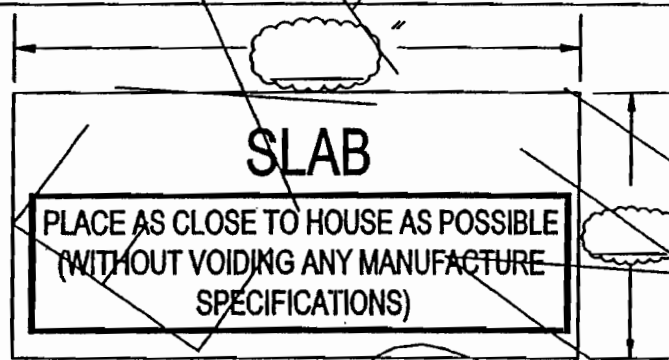

CHECK  REINFORCEMENT STEEL OR MESH

ONE  FIBER CRETE  LT. WT. SLAB

## WIRE & PIPE SIZE W/ BOND

① \_\_\_\_\_

② \_\_\_\_\_

③ \_\_\_\_\_

## TIE DOWN INFO

TYPE & BOLT SIZE \_\_\_\_\_

HOW MANY \_\_\_\_\_

## FUEL CHECK ONE

LP  NATURAL

OTHER \_\_\_\_\_



# DEDICATED SUB-PANEL W/ AUTOMATIC TRANSFER RESIDENTIAL ONLY (N.E.C. 2002 SEC. 702 )

**INFORMATIONAL ONLY NOT FOR PERMITTING**

**NOTE:** Applicant must fill in all clouded areas, check all applicable boxes and open fields for permit submittal

**SCREENING TYPE:**

- EXISTING FENCE
- WOOD FENCE
- CBS WALL
- HEDGES

**SOUND AFFIDAVIT**

FILLED OUT & SIGNED AT TIME OF INSPECTION TO GET A CERTIFICATE OF COMPLETION

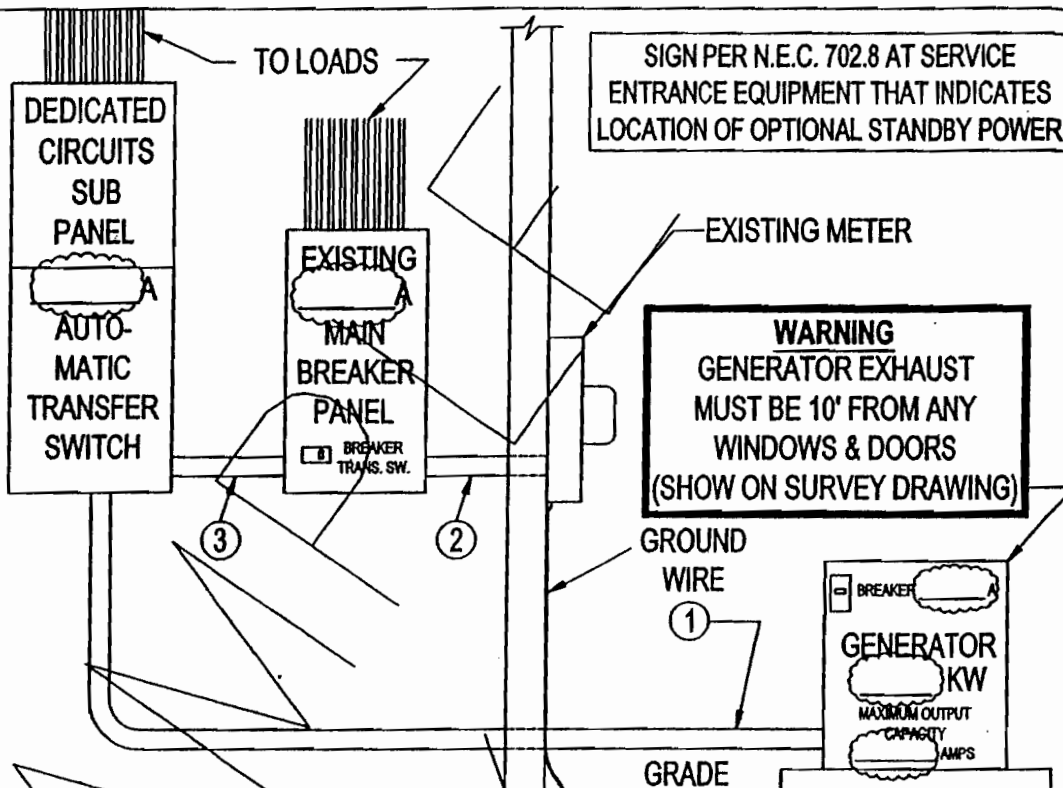

**SLAB & FUEL INFORMATION**

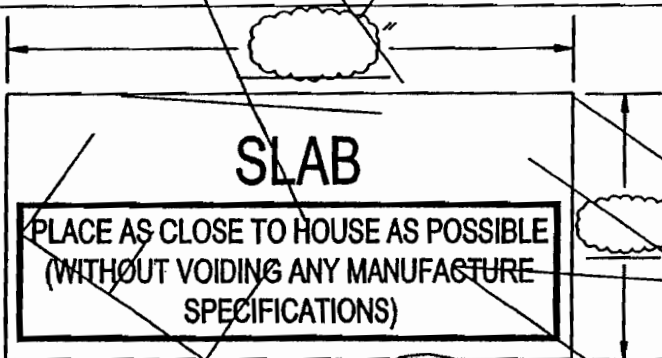

- CHECK ONE
- REINFORCEMENT STEEL OR MESH
  - FIBER CRETE
  - LT. WT. SLAB

**WIRE & PIPE SIZE W/ BOND**

- ① \_\_\_\_\_
- ② \_\_\_\_\_
- ③ \_\_\_\_\_

**TIE DOWN INFO**

TYPE & BOLT SIZE \_\_\_\_\_  
HOW MANY \_\_\_\_\_

**FUEL CHECK ONE**

- LP  NATURAL
- OTHER \_\_\_\_\_

GENERATOR CHECKLIST

APPROVED FOR DISTRIBUTION BY

Revised: 08/17/05

REBECCA D. CALDWELL *Rebecca Caldwell* DATE *8/29/05* BUILDING DIVISION SUPERVISION



Palm Beach County Department of Planning, Zoning & Building
- Building Division -

GENERATOR NOISE - LIMIT COMPLIANCE AFFIDAVIT

This affidavit must be fully executed, and provided to the Inspector at Final Electrical Inspection to receive a Certificate of Completion.

P.R. Number Address

The allowable noise limits in unincorporated Palm Beach County for generators used as optional standby systems during HURRICANE RELATED power outages is not to exceed 75 decibels at the boundary of adjacent owner(s) property.

GENERATOR INFORMATION:

Manufacturer Model # & Size (kw)

Noise Rating (decibels) at (meters/feet)

I (We) certify that the generator being installed at the above address will not exceed 75 decibels at the closest point on adjacent property. This will be achieved through one or more of the following:

- Generator as installed per manufacturer's installation requirements will meet 75 decibel noise limit, with no added sound attenuation measures.
Generator may exceed 75 decibels based on manufacturer's sound rating, and will be installed with one or more added sound attenuation features as described below to insure generator noise level will not exceed 75 decibels on adjacent property.

On (date), a measurement was taken with a sound meter at a height of approximately five feet, and at the closest point of the adjacent property to the generator permitted at the above address. This test was performed with the generator running at its calculated load. The maximum sound level produced was decibels.

Owner and Contractor (if other than Owner/Builder) further acknowledge that additional sound attenuation, relocation of equipment or possible removal from property may be required if noise levels are found to exceed the maximum 75 decibel limit.

Contractor, Owner/Builder, or Florida Registered Engineer (Print) License Number

Qualifier's Name (If Contractor) Qualifier, Owner/Builder, or Engineer Signature Date

APPROVED FOR DISTRIBUTION BY

Rebecca D. Caldwell Rebecca D. Caldwell Date 8/29/05 Building Division Supervisor