

THIS INSTRUMENT WAS PREPARED BY:
 LONDON M. CROSS OF
CARMAHAN-PROCTOR AND ASSOCIATES, INC.
 CONSULTING ENGINEERS
 SURVEYORS ENGINEERS PLANNERS
 6191 WEST ATLANTIC BLVD., MARGATE, FLORIDA 33063
 JANUARY 1993 8706065 JN/JSH

BOCA GREENS (WEST PHASE) P.U.D.

BOCA ISLES WEST PHASE 2B

A PORTION OF SECTION 12, TOWNSHIP 47 SOUTH, RANGE 41 EAST, AND A REPLAT OF PORTIONS OF TRACTS 1, 2 AND 3, SECTION 11, TOWNSHIP 47 SOUTH, RANGE 41 EAST, "FLORIDA FRUIT LANDS COMPANY'S SUBDIVISION NO. 2", (P.B. 1, PG. 102, P.B.C.R.) AND A PORTION OF THE ABANDONED 15.00 FOOT WIDE ROAD RIGHT-OF-WAY (O.R.B. 7699, PGS. 116-121, P.B.C.R.)
PALM BEACH COUNTY, FLORIDA

STATE OF FLORIDA
 COUNTY OF PALM BEACH
 THIS PLAT WAS FILED FOR RECORD AT
 THIS DAY OF _____
 A.D., 199__ AND DULY RECORDED
 IN PLAT BOOK _____ ON PAGES
 AND
 DOROTHY H. WILKEN, CLERK
 BY: _____ DC

SHEET 2 OF 2 SHEETS

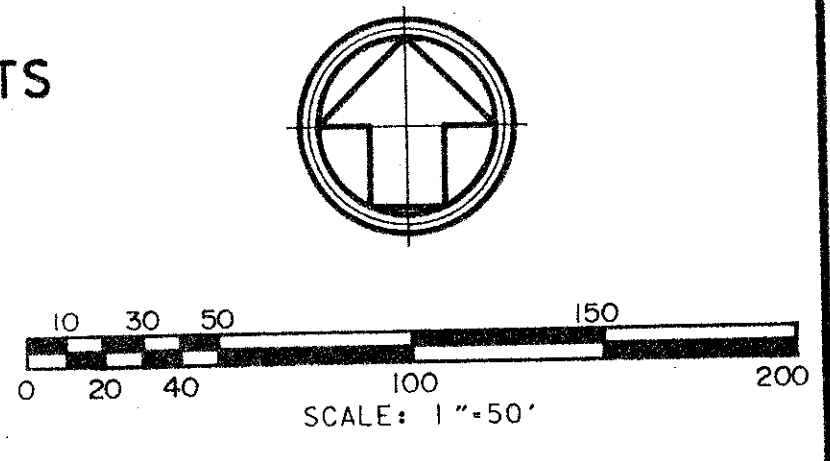

A C R E A G E

- LEGEND:**
- DENOTES SET PERMANENT REFERENCE MONUMENT P.L.S. NO. 3348 (UNLESS OTHERWISE INDICATED)
 - DENOTES PERMANENT CONTROL POINT
 - DENOTES CENTERLINE
 - DENOTES ARC LENGTH
 - DENOTES DELTA (CENTRAL ANGLE)
 - D.E. DENOTES DRAINAGE EASEMENT
 - L.E. DENOTES LANDSCAPE EASEMENT
 - L.M.E. DENOTES LAKE MAINTENANCE EASEMENT
 - U.E. DENOTES UTILITY EASEMENT
 - P.O.C. DENOTES POINT OF COMMENCEMENT
 - P.B.C.R. DENOTES PALM BEACH COUNTY RECORDS
 - P.B. DENOTES PLAT BOOK
 - PG. DENOTES PAGE
 - P.O.B. DENOTES POINT OF BEGINNING
 - P.U.D. DENOTES PLANNED UNIT DEVELOPMENT
 - R. DENOTES RADIUS
 - R.E.E. DENOTES ROOF ENCROACHMENT EASEMENT
 - SF DENOTES SQUARE FEET
 - TYP DENOTES TYPICAL
 - U.E. DENOTES UTILITY EASEMENT
 - P.O.C. DENOTES POINT OF COMMENCEMENT

*PET. 77-131
 ALLOC. \$0001
 5/3/3/M*

0208-012

BOCA ISLES WEST PHASE 2B

70/183

SUBDIVISION * BOCA ISLES WEST PHASE 2B
 BOOK 70
 FLOOD ZONE B
 QUAD * 68
 ZIP CODE 33498
 PUD NAME BOCA GREENS.
 TAZ = BB