

**CARNAHAN · PROCTOR · CROSS, INC.**  
 CONSULTING ENGINEERS · SURVEYORS · PLANNERS  
 6101 WEST ATLANTIC BOULEVARD, MARGATE, FLORIDA 33063  
 PHONE: 954-972-3959 FAX: 954-972-4178

# BOTANICA - REPLAT OF LOTS 120-127

A REPLAT OF LOTS 120-127, "BOTANICA", AS RECORDED IN PLAT BOOK 98, PAGES 28-49, PUBLIC RECORDS OF PALM BEACH COUNTY, FLORIDA, IN SECTION 12, TOWNSHIP 41 SOUTH, RANGE 42 EAST, TOWN OF JUPITER, PALM BEACH COUNTY, FLORIDA

MARCH 2004 SHEET 1 OF 1

# 146

STATE OF FLORIDA  
 COUNTY OF PALM BEACH  
 THIS PLAT WAS FILED FOR RECORD AT 5:00 PM THIS 6th DAY OF MAY 2004, AND DULY RECORDED IN PLAT BOOK 102 ON PAGES 146 THRU 146. DOROTHY H. WILKEN, CLERK  
 BY: *[Signature]*

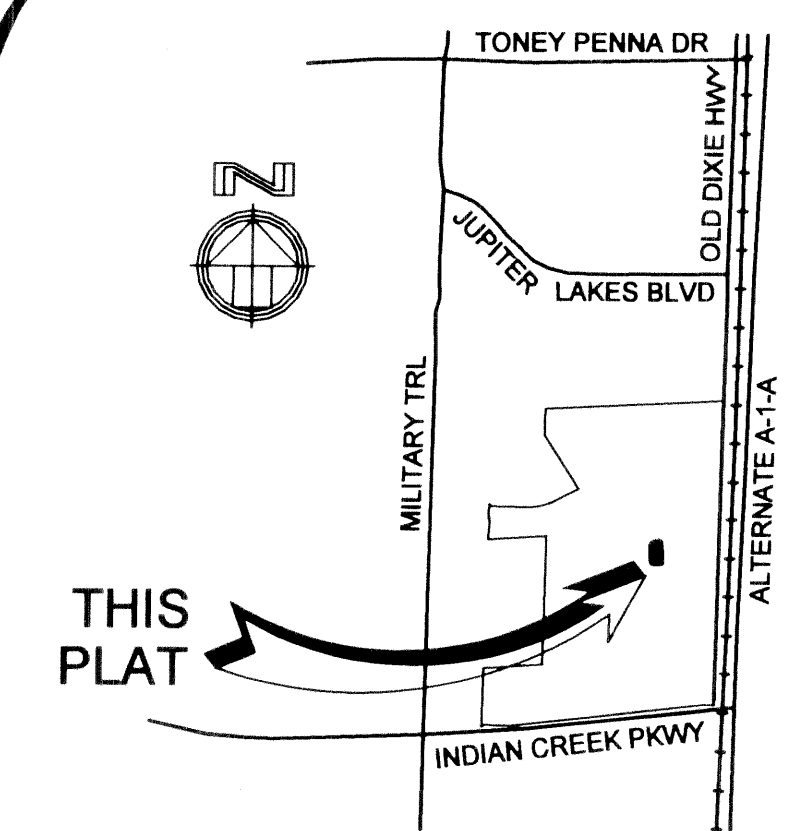

LOCATION MAP  
 NOT TO SCALE

### DESCRIPTION, DEDICATION AND RESERVATION

KNOW ALL MEN BY THESE PRESENTS THAT CENTEX HOMES, A NEVADA GENERAL PARTNERSHIP, AUTHORIZED TO DO BUSINESS IN THE STATE OF FLORIDA, OWNER OF THE LANDS SHOWN HEREON AS "BOTANICA - REPLAT OF LOTS 120-127", AND BEING MORE PARTICULARLY DESCRIBED AS FOLLOWS:  
 LOTS 120 THROUGH 127, INCLUSIVE, "BOTANICA", ACCORDING TO THE PLAT THEREOF AS RECORDED IN PLAT BOOK 98, PAGES 28-49 OF THE PUBLIC RECORDS OF PALM BEACH COUNTY, FLORIDA.  
 SAID LANDS SITUATE IN THE TOWN OF JUPITER, PALM BEACH COUNTY, FLORIDA, AND CONTAIN 0.329 ACRES, MORE OR LESS.  
 HAS CAUSED THE SAME TO BE SURVEYED AND PLATTED AS SHOWN HEREON.

IN WITNESS WHEREOF: CENTEX REAL ESTATE CORPORATION, A NEVADA CORPORATION AUTHORIZED TO DO BUSINESS IN THE STATE OF FLORIDA, MANAGING GENERAL PARTNER OF CENTEX HOMES, A NEVADA GENERAL PARTNERSHIP, HAS CAUSED THESE PRESENTS TO BE SIGNED BY ITS PRESIDENT AND ITS CORPORATE SEAL TO BE AFFIXED HERETO BY AND WITH THE AUTHORITY OF ITS BOARD OF DIRECTORS, THIS 22 DAY OF MAY, 2004.

CENTEX HOMES, A NEVADA GENERAL PARTNERSHIP, AUTHORIZED TO DO BUSINESS IN THE STATE OF FLORIDA BY: CENTEX REAL ESTATE CORPORATION, A NEVADA CORPORATION, MANAGING GENERAL PARTNER, AUTHORIZED TO DO BUSINESS IN THE STATE OF FLORIDA

WITNESS *[Signature]*  
 PRINT NAME: Michael Reynolds

BY: *[Signature]*  
 DAVID E. ABRAMS  
 DIVISION PRESIDENT

WITNESS *[Signature]*  
 PRINT NAME: Scott M. CLEMENTS

### TITLE CERTIFICATION

STATE OF FLORIDA ) SS  
 COUNTY OF PALM BEACH )  
 WE, COMMERCE TITLE COMPANY, A TITLE INSURANCE COMPANY, DULY LICENSED IN THE STATE OF FLORIDA, DO HEREBY CERTIFY THAT WE HAVE EXAMINED THE TITLE TO THE HERON DESCRIBED PROPERTY; THAT WE FIND THE TITLE TO THE PROPERTY IS VESTED IN CENTEX HOMES; THAT THE CURRENT TAXES HAVE BEEN PAID; THAT THERE ARE NO MORTGAGES OF RECORD; AND THAT THERE ARE ENCUMBRANCES OF RECORD BUT THOSE ENCUMBRANCES DO NOT PROHIBIT THE CREATION OF THE SUBDIVISION DEPICTED BY THIS PLAT.

BY: *[Signature]* 5-22-04  
 DATE  
 NAME: Rebecca B. Winter  
 TITLE: Vice Pres.

### TOWN OF JUPITER ACCEPTANCE

THIS PLAT IS HEREBY APPROVED FOR RECORD PURSUANT TO THE ORDINANCES THE TOWN OF JUPITER, AND IN ACCORDANCE WITH SECTION 177.07 (2), FLORIDA STATUTES, THIS 22 DAY OF MAY, 2004, AND HAS BEEN REVIEWED BY A PROFESSIONAL SURVEYOR AND MAPPER UNDER CONTRACT WITH THE TOWN OF JUPITER, IN ACCORDANCE WITH SECTION 177.081 (1), FLORIDA STATUTES.

BY: *[Signature]*  
 DOUG P. KOENNICKE, P.E., TOWN ENGINEER

"BOTANICA - REPLAT OF LOTS 120-127" IS HEREBY APPROVED FOR RECORD THIS 22 DAY OF MAY, 2004.

BY: *[Signature]*  
 KAREN J. GOLONIKA, MAYOR

ATTEST: *[Signature]*  
 SALLY M. BOYLAN, TOWN CLERK

### NOTES:

- BEARINGS SHOWN HEREON ARE BASED ON AND RELATIVE TO THE BEARING OF NORTH 90°00'00" WEST ALONG THE SOUTH LINE OF LOT 120, "BOTANICA", AS RECORDED IN PLAT BOOK 98, PAGES 28-49, PUBLIC RECORDS OF PALM BEACH COUNTY, FLORIDA.
- NO STRUCTURES OR BUILDINGS OF ANY KIND OR LANDSCAPING SHALL BE PLACED ON OR WITHIN ANY EASEMENT WITHOUT THE PRIOR WRITTEN CONSENT OF ALL EASEMENT BENEFICIARIES AND THE TOWN ENGINEER.
- NOTICE: THIS PLAT, AS RECORDED IN ITS GRAPHIC FORM, IS THE OFFICIAL DEPICTION OF THE SUBDIVIDED LANDS DESCRIBED HEREIN AND WILL IN NO CIRCUMSTANCES BE SUPPLANTED IN AUTHORITY BY ANY OTHER GRAPHIC OR DIGITAL FORM OF THE PLAT. THERE MAY BE ADDITIONAL RESTRICTIONS THAT ARE NOT RECORDED ON THIS PLAT THAT MAY BE FOUND IN THE PUBLIC RECORDS OF THIS COUNTY.

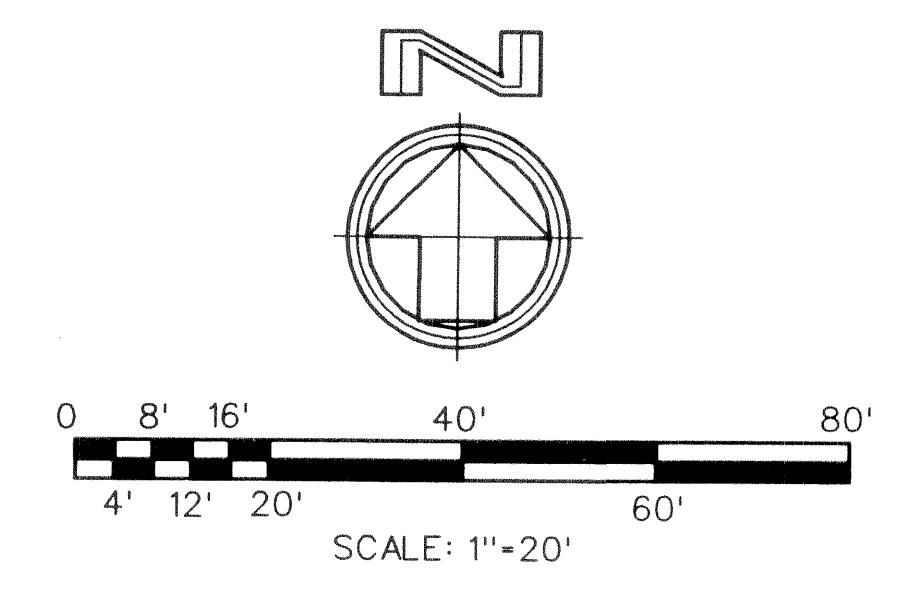

### LEGEND:

- SET P.R.M.: 4" DIAMETER CONCRETE MONUMENT W/CAP LB2936
- ⊕ CENTERLINE
- \* EASEMENTS CREATED BY "BOTANICA", PLAT BOOK 98, PAGES 28-49

### ABBREVIATIONS:

- A = ARC LENGTH
- D = DELTA (CENTRAL ANGLE)
- (N.R.) = NON-RADIAL
- P.B. = PLAT BOOK
- PG. = PAGE(S)
- P.R.M. = PERMANENT REFERENCE MONUMENT
- R = RADIUS
- S.S.E. = SAFE SIGHT EASEMENT
- U.E. = UTILITY EASEMENT

### ACREAGE TABLE

LOT #	AREA (IN ACRES)
120	0.055
121	0.035
122	0.035
123	0.035
124	0.035
125	0.035
126	0.035
127	0.063
TOTAL	0.329

### SURVEYOR'S CERTIFICATE

THIS IS TO CERTIFY THAT THE PLAT SHOWN HEREON WAS PREPARED UNDER MY DIRECTION AND SUPERVISION AND IS A TRUE AND CORRECT REPRESENTATION OF A SURVEY MADE UNDER MY RESPONSIBLE DIRECTION AND SUPERVISION; THAT SAID SURVEY IS ACCURATE TO THE BEST OF MY KNOWLEDGE AND BELIEF; THAT PERMANENT REFERENCE MONUMENTS ("P.R.M.'S") HAVE BEEN PLACED AS REQUIRED BY LAW AND THAT MONUMENTS ACCORDING TO SEC. 177.091 (9), F.S., WILL BE PLACED AS REQUIRED BY LAW; AND, FURTHER, THAT THE SURVEY DATA COMPLIES WITH ALL THE REQUIREMENTS OF CHAPTER 177, FLORIDA STATUTES, AS AMENDED, AND THE ORDINANCES OF THE TOWN OF JUPITER, FLORIDA.

*[Signature]* 5-28-04  
 DONNA C. WEST DATE  
 PROFESSIONAL SURVEYOR AND MAPPER  
 FLORIDA CERTIFICATE NO. LS4290  
 CARNAHAN PROCTOR CROSS, INC.  
 6101 W. ATLANTIC BLVD.  
 MARGATE, FL 33063  
 CERTIFICATE OF AUTHORIZATION NO. LB2936

### ACKNOWLEDGEMENT

STATE OF FLORIDA ) SS  
 COUNTY OF PALM BEACH )  
 BEFORE ME PERSONALLY APPEARED DAVID E. ABRAMS, WHO IS PERSONALLY KNOWN TO ME OR HAS PRODUCED *[Signature]* AS IDENTIFICATION, AND WHO EXECUTED THE FORGOING INSTRUMENT AS DIVISION PRESIDENT OF CENTEX REAL ESTATE CORPORATION, A NEVADA CORPORATION, AND ACKNOWLEDGED TO AND BEFORE ME THAT HE EXECUTED SUCH INSTRUMENT AS SUCH OFFICER OF SAID CORPORATION, AND THAT THE SEAL AFFIXED TO THE FOREGOING INSTRUMENT IS THE CORPORATE SEAL OF SAID CORPORATION AND THAT IT WAS AFFIXED TO SAID INSTRUMENT BY DUE AND REGULAR CORPORATE AUTHORITY, AND THAT SAID INSTRUMENT IS THE FREE ACT AND DEED OF SAID CORPORATION.  
 WITNESS MY HAND AND OFFICIAL SEAL THIS 20 DAY OF May, 2004.

MY COMMISSION EXPIRES: March 17, 2006 *[Signature]*

NOTARY PUBLIC-STATE OF FLORIDA  
 COMMISSION NO. DD 073152



CENTEX REAL ESTATE CORP.	SURVEYOR	TOWN ENGINEER	TOWN OF JUPITER
<i>[Signature]</i>	<i>[Signature]</i>	<i>[Signature]</i>	<i>[Signature]</i>

