

CARNAHAN · PROCTOR · CROSS, INC.

CONSULTING ENGINEERS · SURVEYORS · PLANNERS

6101 WEST ATLANTIC BOULEVARD, MARGATE, FLORIDA 33063
PHONE: 954-972-3959 FAX: 954-972-4178

SEPTEMBER 2003

990901-5

JJM

EVERGRENE P.C.D. PLAT NINE

A REPLAT OF TRACT F-5, "EVERGRENE PLAT TWO" AS RECORDED IN PLAT BOOK 95 AT PAGES 29 THROUGH 54 OF THE PUBLIC RECORDS OF PALM BEACH COUNTY, FLORIDA IN SECTION 25, TOWNSHIP 41 SOUTH, RANGE 42 EAST CITY OF PALM BEACH GARDENS, PALM BEACH COUNTY, FLORIDA

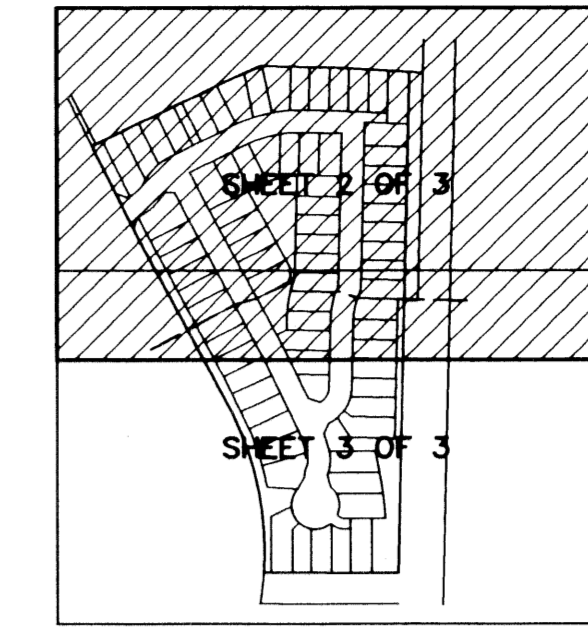

KEY MAP
NOT TO SCALE

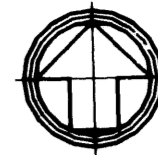

125

SHEET 2 OF 3

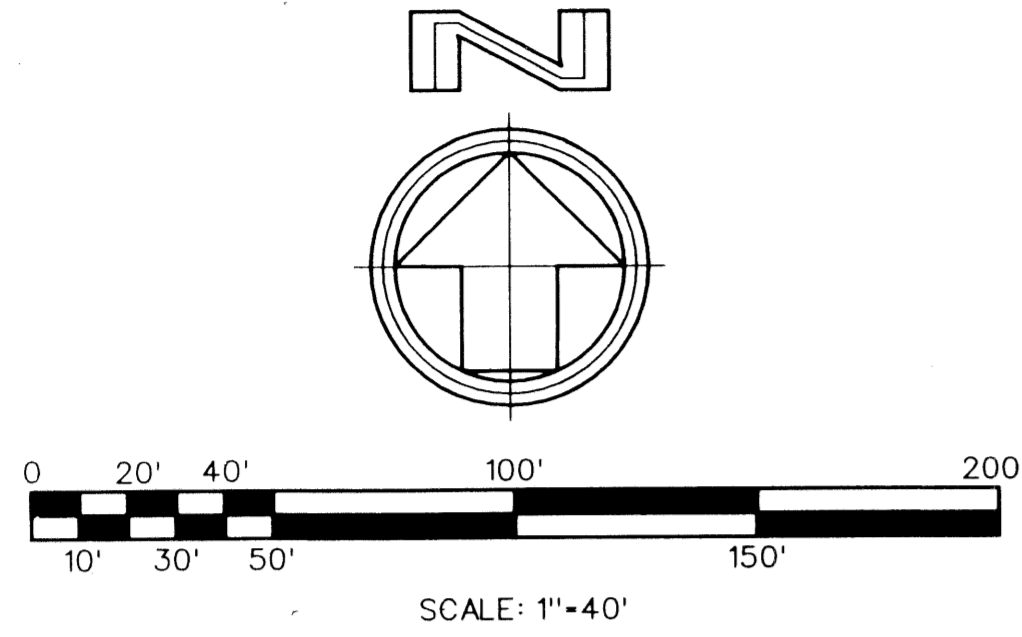

SCALE: 1"=40'

WATER MANAGEMENT TRACT WM-2
"EVERGRENE PLAT TWO"
(P.B. 95, PGS. 29-54)

"EVERGRENE PLAT TWO"
(P.B. 95, PGS. 29-54)

WATER MANAGEMENT TRACT WM-8
70' NPBCID, D.E.
(O.R.B. 29/4, PG. 670)

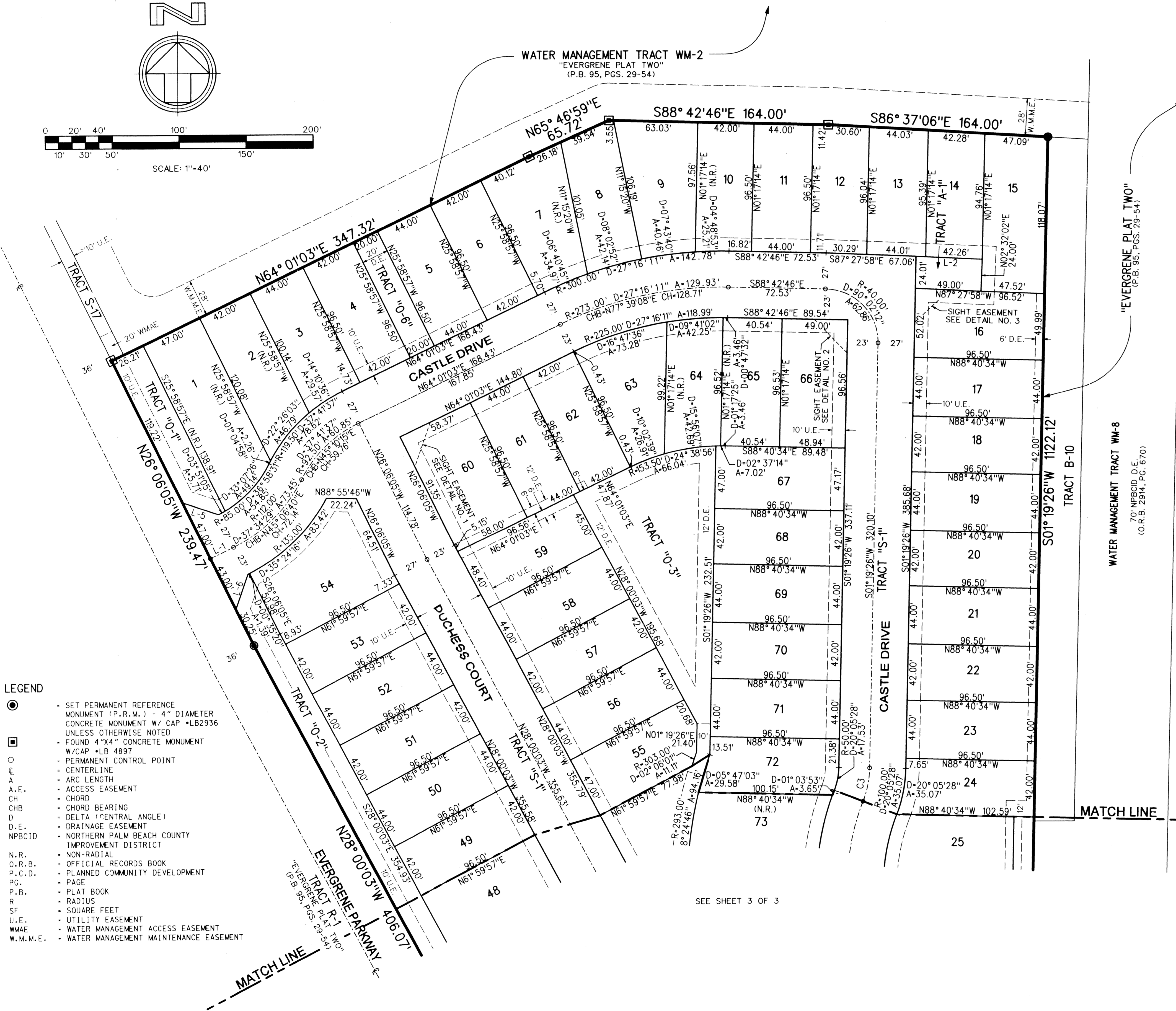

CURVE TABLE					
	RADIUS	CENTRAL ANGLE	ARC LENGTH	CHORD BEARING	CHORD
C1	R-42.00'	D-36° 56' 23"	A-27.08'	CHB-N71° 24' 29"W	CH-26.61'
C2	R-18.00'	D-19° 26' 23"	A-6.11'	CHB-N62° 39' 29"W	CH-6.08'
C3	R-73.00'	D-20° 05' 28"	A-25.60'	CHB-S11° 22' 10"W	CH-25.47'
C4	R-173.50'	D-20° 05' 28"	A-60.84'	CHB-S11° 22' 10"W	CH-60.53'
C5	R-60.00'	D-63° 21' 06"	A-66.34'	CHB-S32° 59' 59"W	CH-63.01'
C6	R-40.00'	D-19° 20' 39"	A-13.50'	CHB-N12° 13' 12"E	CH-13.44'
C7	R-65.00'	D-36° 07' 36"	A-40.98'	CHB-N03° 49' 44"E	CH-40.31'

LINE TABLE		
	BEARING	DISTANCE
L-1	N63° 53' 55"E	19.32'
L-2	S87° 27' 58"W	49.51'
L-3	N89° 52' 40"W	13.95'
L-4	S00° 07' 20"W	24.00'
L-5	S71° 24' 04"E	28.43'
L-6	S18° 46' 22"W	28.22'

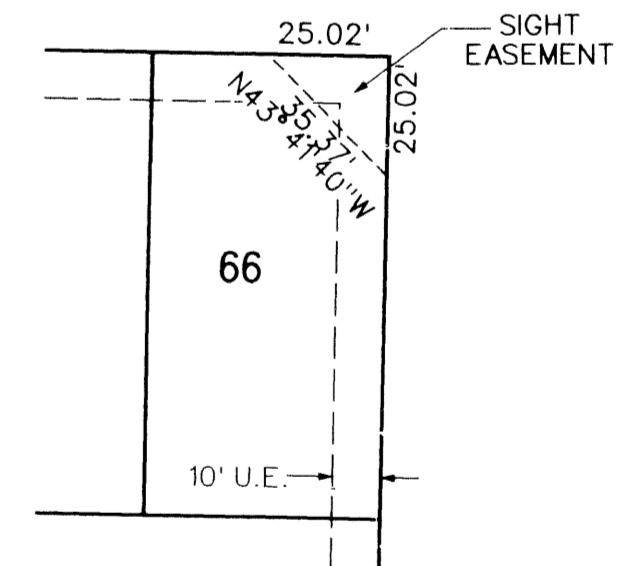

DETAIL NO. 2
SIGHT EASEMENT

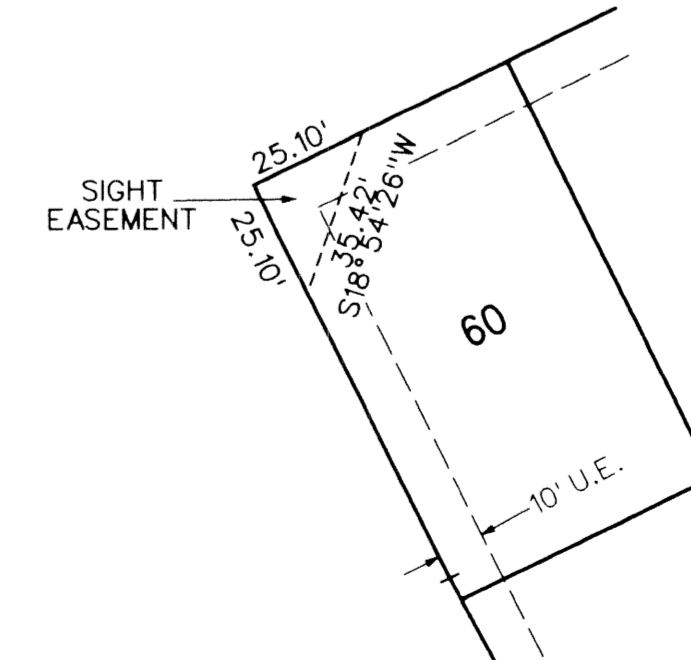

DETAIL NO. 1
SIGHT EASEMENT

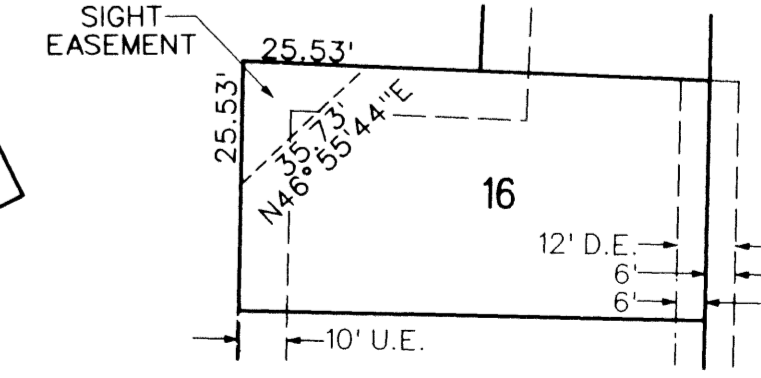

DETAIL NO. 3
SIGHT EASEMENT

LEGEND

- SET PERMANENT REFERENCE MONUMENT (P.R.M.) - 4" DIAMETER CONCRETE MONUMENT W/ CAP +LB2936 UNLESS OTHERWISE NOTED
- FOUND 4"x4" CONCRETE MONUMENT W/CAP +LB 4897
- PERMANENT CONTROL POINT
- CENTERLINE
- A ARC LENGTH
- A.E. ACCESS EASEMENT
- CH CHORD
- CHB CHORD BEARING
- D DELTA (CENTRAL ANGLE)
- D.E. DRAINAGE EASEMENT
- NPBCID NORTHERN PALM BEACH COUNTY IMPROVEMENT DISTRICT
- N.R. NON-RADIAL
- O.R.B. OFFICIAL RECORDS BOOK
- P.C.D. PLANNED COMMUNITY DEVELOPMENT
- PG. PAGE
- P.B. PLAT BOOK
- R RADIUS
- SF SQUARE FEET
- U.E. UTILITY EASEMENT
- WMAE WATER MANAGEMENT ACCESS EASEMENT
- W.M.M.E. WATER MANAGEMENT MAINTENANCE EASEMENT

SEE SHEET 3 OF 3