

ACCESS MANAGEMENT STANDARDS

FOR COUNTY ROADS ON THE

THOROUGHFARE RIGHT OF WAY

IDENTIFICATION MAP

PRODUCED BY:

PALM BEACH COUNTY ENGINEERING

AND

PUBLIC WORKS DEPARTMENT

Updated August 2021

Roadway Classifications

For the purposes of access management all County maintained roadways shown on the Thoroughfare Right of Way Identification Map shall be classified into one of two categories:

- 80' Right Of Way Undivided Collector Roadway Constructed To 5 Lane Section or 80' Right Of Way Collector Roadway With Islands Constructed To 4/5 Lane Section.
- 100' Or Greater Right Of Way Divided Arterial Roadway

80' Right Of Way Undivided Collector Roadways Or Collector Roadways With Islands have a 5 lane curb and gutter typical section with sidewalks on both sides. The center lane on such County roadways is marked for two-way left turns, except for the islands or where conditions indicate that dedicated one-way turn lanes should be provided. One-way turn lanes would be provided for signalized intersections and in locations where physical barriers (such as adjacent parallel canals) preclude turning in one direction.

Such roadways are intended to be expanded to provide separate right turn lanes at intersections with other Thoroughfare Plan Roadways. Roadway may have a median and dual left turn lanes at the intersection with Thoroughfare Plan Roadways if required by the traffic volumes.

In the cases of 80' right of way roads that have not been built to their ultimate sections, the spacing of connections and turn lanes shall be based on the ultimate design section for the roadway.

100' Or Greater Right Of Way Divided Arterial Roadways include all divided County roadways shown on the Thoroughfare Plan whose rights of way are 100' or greater. Typically, these roadways have 4 or more lane ultimate sections, but in some cases may have up to 8 lanes. In either case, the ultimate sections have median and outside curb and gutter, and sidewalks are generally provided on both sides of the roadway. Left turn lanes are accommodated within the medians of these roadways.

Such roadways are intended to be expanded to provide separate right turn lanes and dual left turn lanes at their intersections with other Thoroughfare Plan Roadways.

In the cases of 100' or greater right of way roads that have not been built to their ultimate sections, the spacing of connections and turn lanes shall be based on the ultimate design section for the roadway.

DUAL LEFT TURN LANES (FULL MEDIAN OPENING)

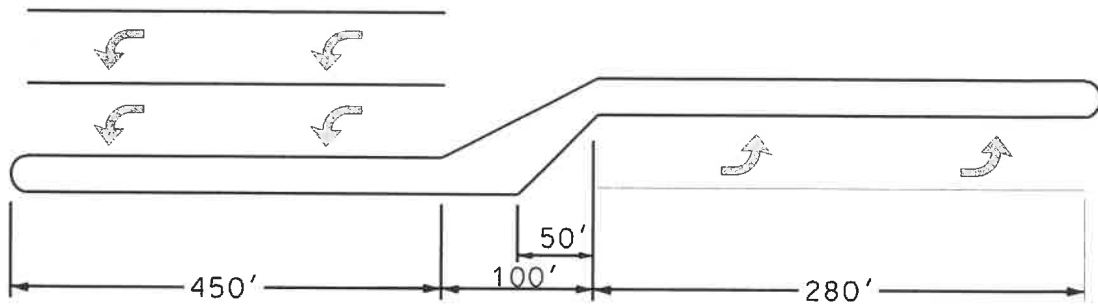

SINGLE LEFT TURN LANES (FULL MEDIAN OPENING)

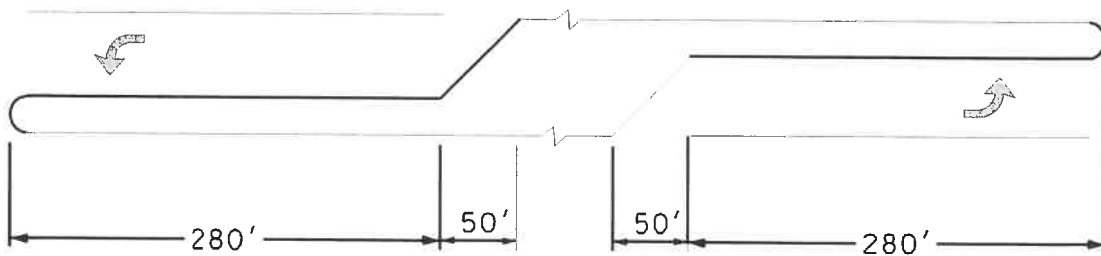

DUAL LEFT TURN LANES (DIRECTIONAL MEDIAN OPENING)

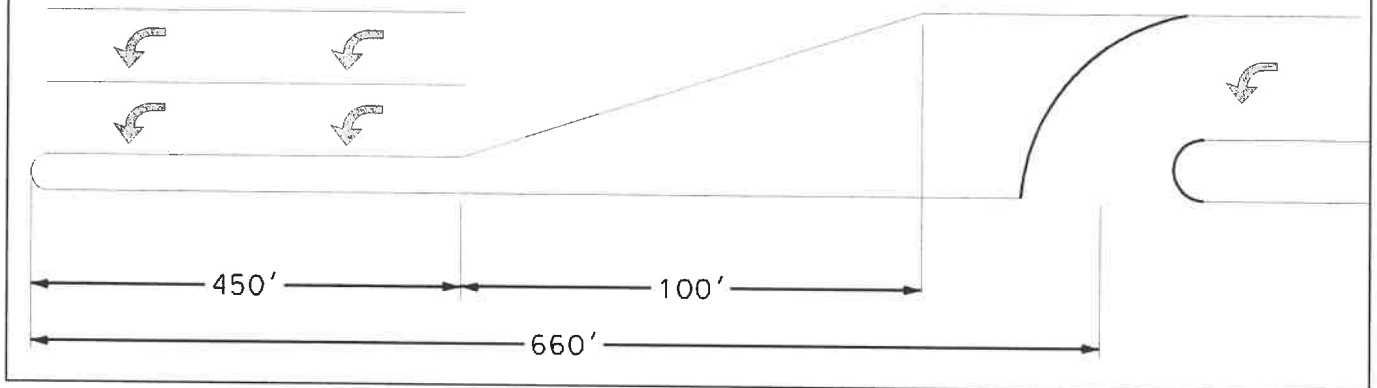

LEFT TURN LANE (DIRECTIONAL MEDIAN OPENING)

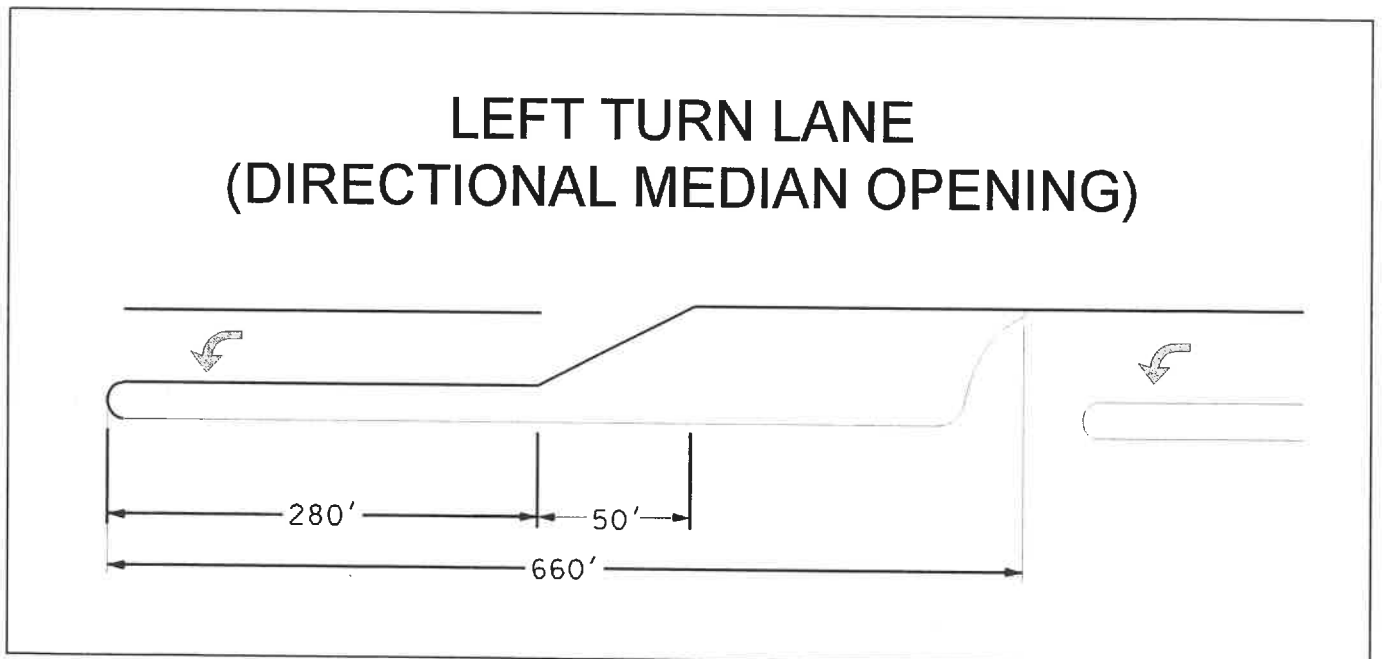

DRAWING NOT TO SCALE

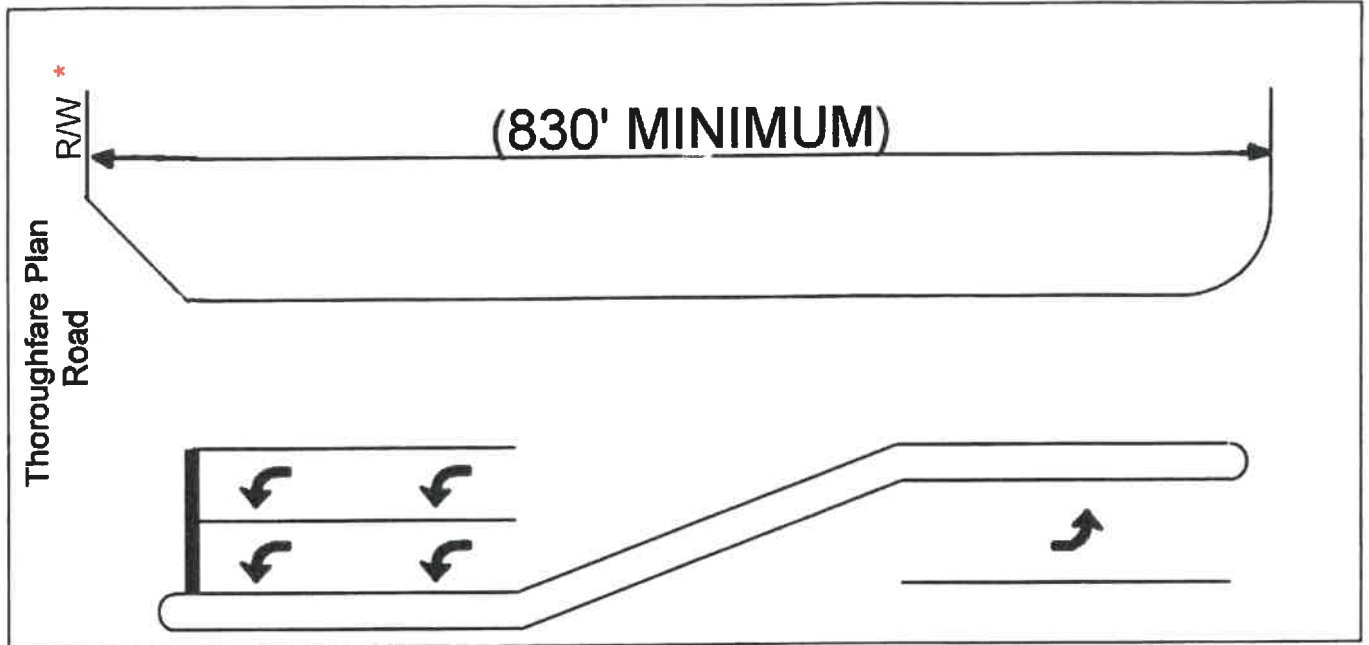

DISTANCE BETWEEN DUAL LEFT TURN LANES AND FIRST MEDIAN OPENING

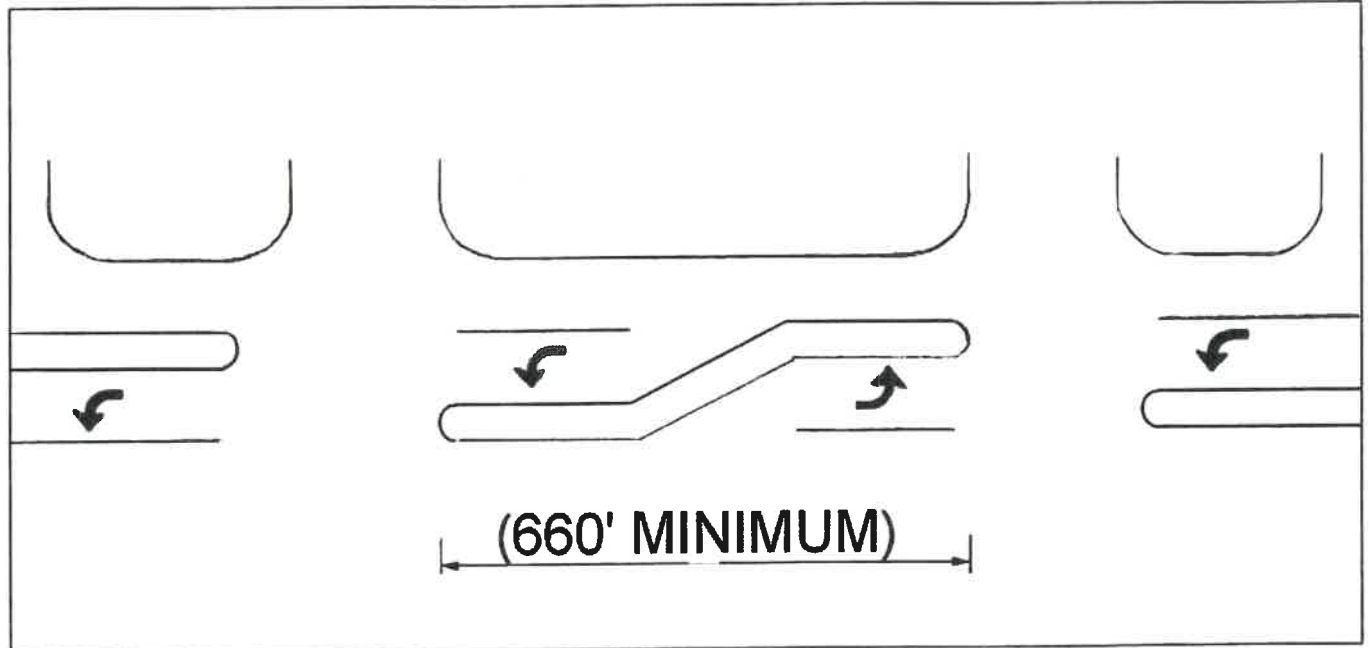

DISTANCE BETWEEN MEDIAN OPENINGS

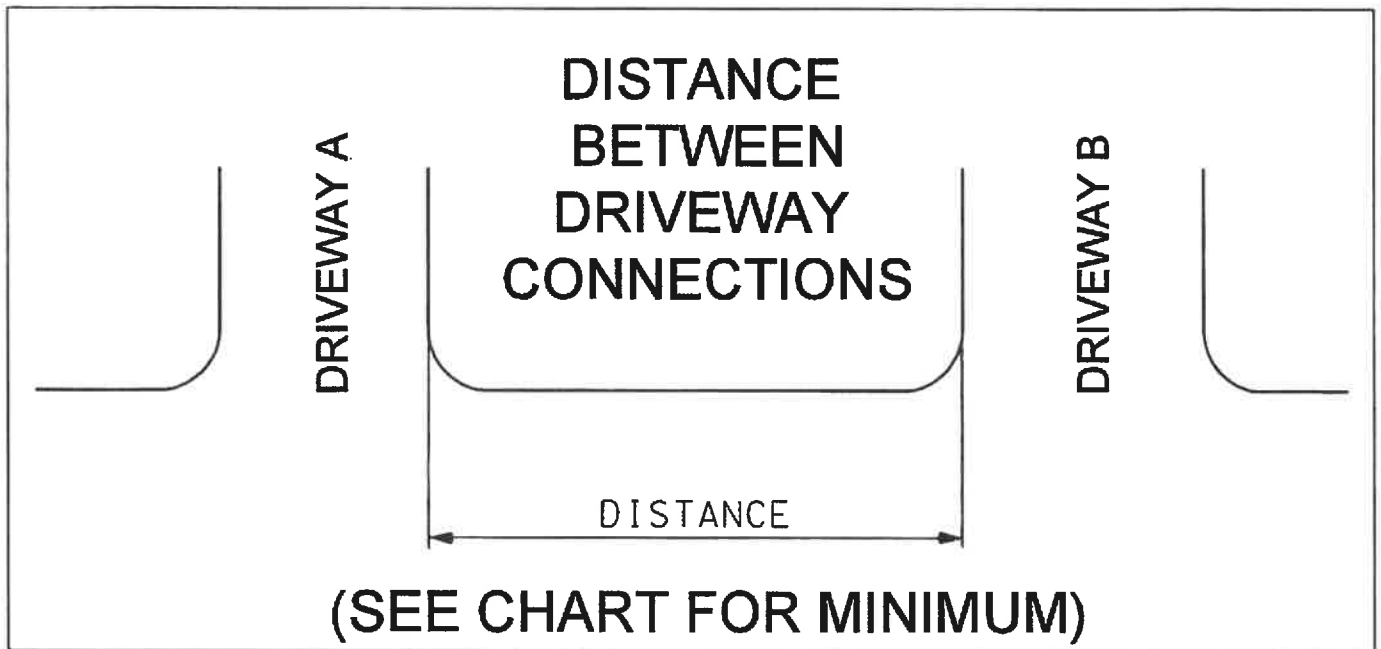
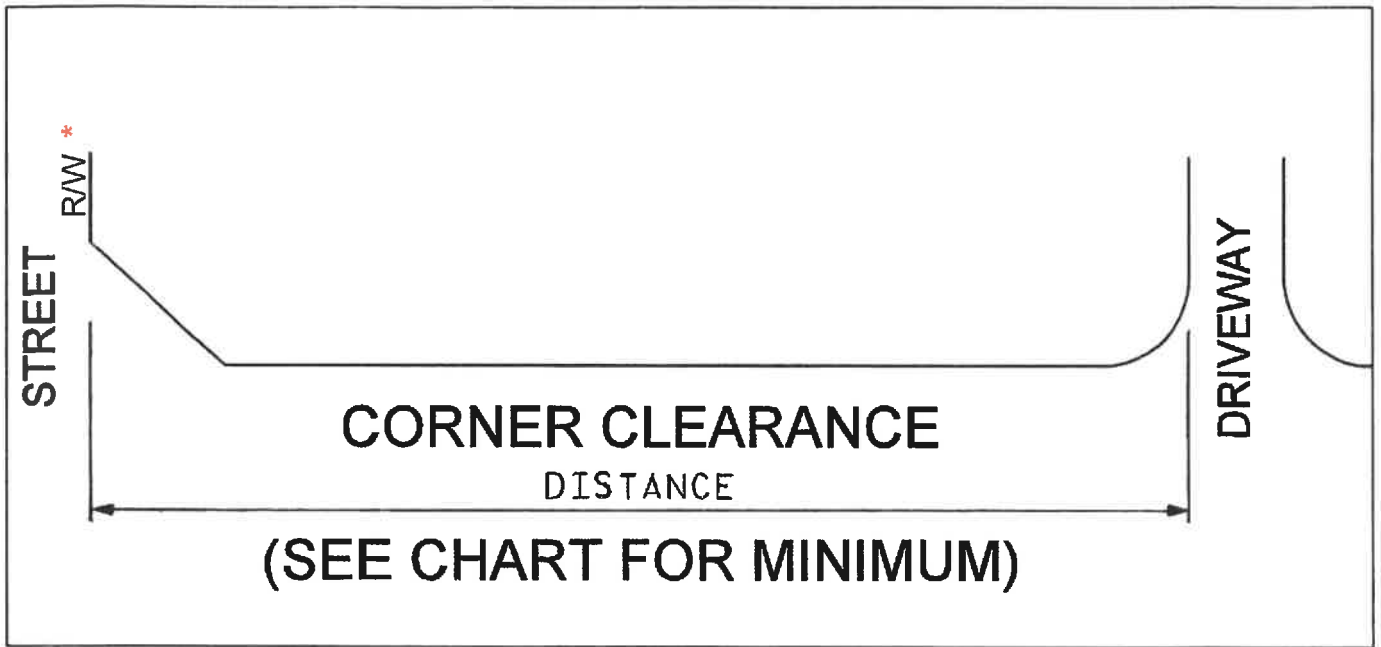

ACCESS MANAGEMENT MINIMUM DIMENSIONS

Roadway Classification	Corner Clearance Distance (Minor St)	Corner Clearance Distance (Thoroughfare Plan Road)	Driveway Connection Spacing	Median Opening (Full)	Median Opening (Directional)	Median Opening (Expanded Intersection) (Full)	Median Opening (Exp. Int. Directional)	Signal Spacing
80' R/W Collector	50'	75' **	125' *	N/A	N/A	N/A	N/A	.25 mile
80' R/W Collector with islands	50'	125' **	125' *	N/A	N/A	N/A	N/A	.25 mile
100' or Greater Arterial	75'	125' **	245' *	660'/830'	660'	830'	660'	.5 mile

All stated dimensions are minimums

On roads not built to their ultimate sections, spacing is to be in accordance with ultimate roadway classification.

* This is the minimum spacing allowed between driveways. The number of driveways to serve a site shall be kept to a minimum and shall be evaluated on a case by case basis.

** Egress high volume (>500 ADT) driveway shall not be located within designated right turn lane. Even where no right turn lane exists, the egress from a high volume driveway shall not be located within 200 feet of an intersection.