

**CONSTRUCTION PROCEDURES**

THE BACKFILL FOR THE FIRST AND SECOND STAGES SHALL BE PLACED IN 6" LAYERS (COMPACTED THICKNESS) AND SHALL BE COMPACTED TO 100% OF MAXIMUM DENSITY AS DETERMINED BY AASHTO T-99.

**STAGE 1:**

THE CONTRACTOR SHALL PROVIDE ADEQUATE COMPACTED FILL BENEATH THE HAUNCHES OF THE PIPE, USING MECHANICAL TAMPS SUITABLE FOR THIS PURPOSE. THIS COMPACTION APPLIES TO THE MATERIAL PLACED BENEATH THE HAUNCHES OF THE PIPE AND ABOVE ANY BEDDING REQUIRED.

**STAGE 2:**

THE CONTRACTOR SHALL OBTAIN A WELL-COMPACTED BED AND FILL ALONG THE SIDES OF THE PIPE AND TO A POINT INDICATING THE TOP OF SUB-GRADE MATERIAL.

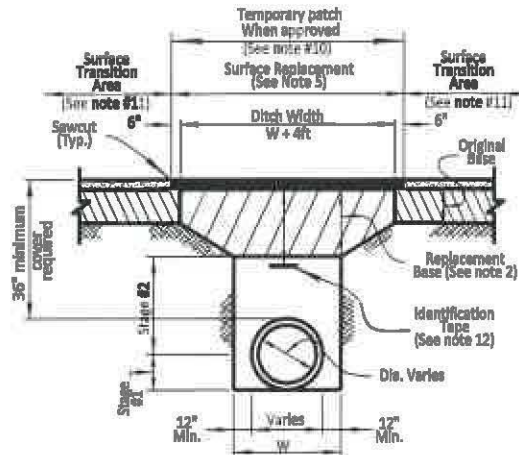

**REPLACEMENT OF FLEXIBLE PAVEMENT FOR PERMITTED PAVEMENT CUT**

**NOTES**

- 1) BEDDING SHALL CONSIST OF IN-SITU GRANULAR MATERIAL OR WASHED AND GRADED LIMEROCK 3/8" - 7/8" SIZING WITH EQUAL OR GREATER STRUCTURAL ADEQUACY AS EXISTING. UNSUITABLE IN-SITU MATERIALS SUCH AS MUCK, DEBRIS AND LARGER ROCKS SHALL BE REMOVED.
- 2) REPLACED BASE MATERIAL OVER DITCH SHALL BE 16" LIMEROCK (LBR100) MINIMUM FOR THOROUGHFARE PLAN ROADS. ANY ALTERNATE BASE MATERIAL REQUESTED BY THE ENGINEER OF RECORD REQUIRES APPROVAL BY THE ROADWAY PRODUCTION DIVISION.
- 3) ASPHALT CONCRETE PAVEMENT JOINTS SHALL BE MECHANICALLY SAWED AND BUTT-JOINTED.
- 4) BASE MATERIAL (PER ROADWAY PRODUCTION DESIGN STANDARDS) SHALL BE PLACED IN TWO OR THREE LAYERS (6" MAX. PER LAYER) AND EACH LAYER THOROUGHLY ROLLED OR TAMPED TO THE SPECIFIED DENSITY. (MINIMUM 98% AASHTO - T-180)
- 5) 1" FRICTION COURSE FC-9.5 OVER 1-1/2" TYPE SP STRUCTURAL COURSE (TRAFFIC LEVEL C) WITH TACK COAT AT 0.05 GAL/SY AND RC-70 PRIME COAT AT 0.10 GAL/SY FOR LIMEROCK BASE. FOLLOW THE LATEST FDOT SPECIFICATIONS FOR APPLICATION RATES OF PRIME AND TACK COATS. CONTRACTOR TO SUBMIT MATERIALS AND RATES TO ENGINEER FOR APPROVAL PRIOR TO BEGINNING WORK
- 6) PIPE SHALL BE PLACED IN A DRY TRENCH.
- 7) ALL ROADWAY REPAIR WORK SHALL BE PERFORMED IN CONFORMANCE WITH APPLICABLE FDOT STANDARD SPECIFICATIONS FOR ROAD AND BRIDGE CONSTRUCTION AND COUNTY PPM# EL-0-3605.
- 8) DENSITY TESTS SHALL BE TAKEN IN 1 FT LIFTS ABOVE THE PIPE AT INTERVALS OF 400 FT MAXIMUM (1 SET MINIMUM) OR AS DIRECTED BY THE CONSTRUCTION COORDINATION DIVISION. RESULTS SHALL BE SUBMITTED TO CONSTRUCTION COORDINATION DIVISION AS PART OF THEIR FIELD REVIEW.
- 9) ENGINEER-OF-RECORD SHALL PROVIDE FULL-TIME INSPECTION DURING THE ENTIRETY OF THE OPEN-CUT OPERATION, BEGINNING WITH THE EXCAVATION AND CONTINUING THROUGH THE COMPLETION OF THE PAVING.
- 10) IF THE PAVEMENT IS NOT COMPLETELY RESTORED IMMEDIATELY FOLLOWING THE OPEN CUT, A SMOOTH TEMPORARY PATCH (MINIMUM 1.5" SP 12.5 STRUCTURAL COURSE ASPHALT) SHALL BE INSTALLED, PROPERLY MATCHING THE EXISTING GRADING OF THE ROADWAY. THE TEMPORARY PATCH SHALL BE ALLOWED TO REMAIN IN PLACE AND BE MAINTAINED FOR A PERIOD NO LONGER THAN 45 DAYS. THE COUNTY RETAINS THE RIGHT TO USE POSTED SURETY TO COMPLETE ANY RESTORATION WORK THAT HAS NOT BEEN COMPLETED IN THE 45 DAY PERIOD. ALTERNATIVE TEMPORARY TRENCH PROTECTION (STEEL PLATES OR OTHERS) MAY BE APPROVED BY THE CONSTRUCTION COORDINATION DIVISION .
- 11) FOR FINAL RESTORATION (INCLUDES THE PATCHED/SURFACE REPLACEMENT AREA OVER THE TRENCH). THE ROAD SHALL BE MILLED/RESURFACED PER NOTE 5 ABOVE FOR A FULL LANE WIDTH OF THE TRAVEL LANES ENCLOSED BY THE TRENCH AREA, INCLUDING A TRANSITION AREA OF 50 FT ON EACH SIDE MEASURED FROM TOP OF TRENCH.
- 12) APPROVED MAGNETIC TAPE IS REQUIRED FOR ALL MAIN PRESSURE PIPES AND CONDUIT IN THE COUNTY'S RIGHT-OF-WAY. INSTALL TAPE 24" BELOW FINISHED GRADE.
- 13) CONTINUOUS 4" WIDE PAINT STRIPING IS REQUIRED FOR DIP/PCCP WATER MAINS (BLUE), SANITARY MAINS (GREEN), DIP RECLAIMED WATER MAINS (PURPLE), GAS MAINS (YELLOW), OR AS REQUIRED BY THE APWA.

FILEPATH: P:/DGN/ENG\_SER/LAND DEVELOPMENT STANDARDS/2.DGN

PALM BEACH COUNTY DEPARTMENT OF ENGINEERING & PUBLIC WORKS				OPEN CUT DETAIL FOR THOROUGHFARE ROADS (PAVED AREAS)		DRAWING NO.  2
DRAWN BY:	DATE:	REVISED BY:	DATE:	APPROVED:	EFFECTIVE:	
K.L.	06/25/93	J.M.K.	02/01/2018	<i>[Signature]</i>	4/27/18	
				COUNTY ENGINEER OR DESIGNEE		