

Project Entrance Sign

N.T.S.

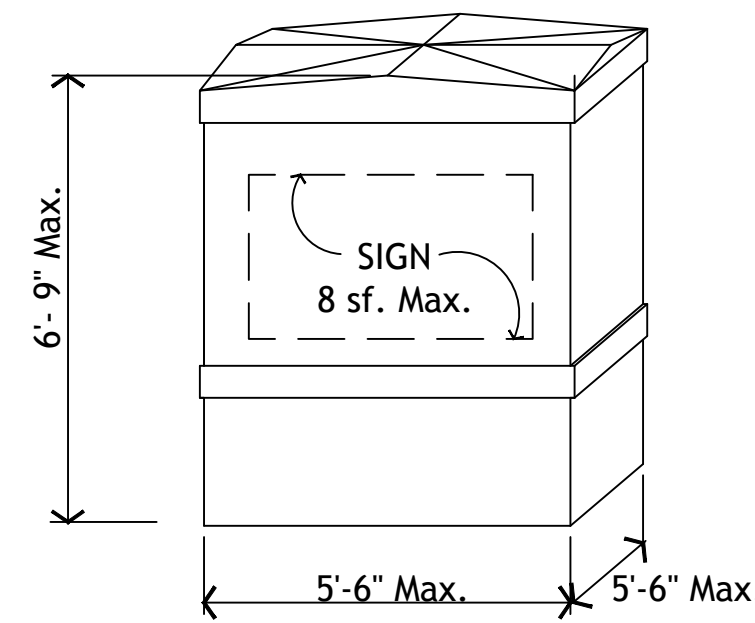

On-POD Directional Sign (Pod Entry Sign)

N.T.S.

PROJECT IDENTIFICATION SIGN - MONUMENT TYPE - SINGLE FACE PERMITTED
 MAXIMUM SIGN AREA - 24 SF.
 MAXIMUM HEIGHT - 6'
 MINIMUM SETBACK - 10'

NOTE:
 PER ULDC TABLE 8.G.3.E.-14 IF A DECORATIVE BACKGROUND ELEMENT SUCH AS TILE, STUCCO OR OTHER BUILDING MATERIAL OR COLOR IS USED, THE MAXIMUM SIGN FACE AREA FOR SUCH DECORATIVE TREATMENT MAY BE EXPANDED 24 INCHES, MEASURED FROM THE SIGN FACE AREA IN EACH CARDINAL DIRECTION.



Project Identification Sign - Property corners

NTS

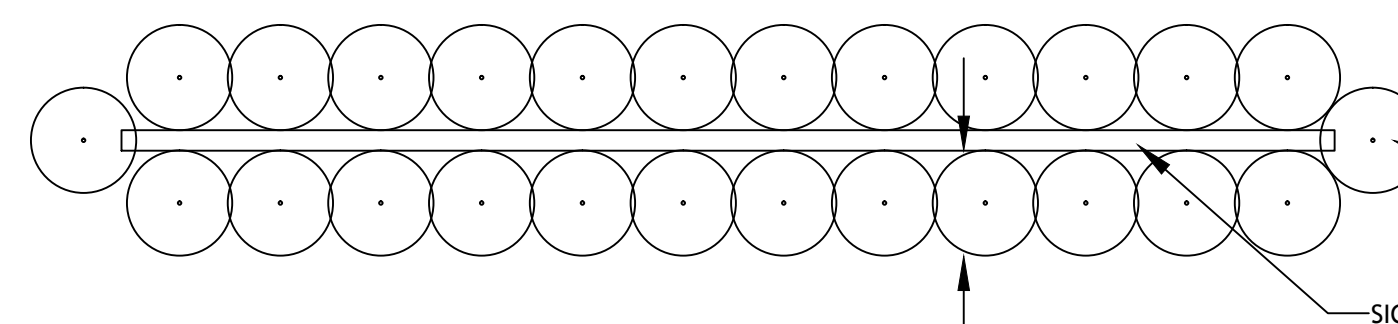

Typical Sign Foundation Planting Detail

NTS

Indian Trails Grove - Master Sign Plan		
Entrance Signs - Art. 8.G.2.C		
	Permitted	Provided
Max. No.	2 per entrance	2 for every entrance from exterior roads (Total number to be determined)
Sign Face	60 SF	60 SF
Max. Ht.	8 feet	8 feet
Add. Ht. Option	Max. sign height, excluding height of structure to which the sign is attached may be increased up to 10' for a RW greater than 80' or up to 110', or 12' for a RW greater than 110'. Subject to a 25' setback.	to be determined
Setback	25 feet if added height	25 feet
Location	Within 100 feet of entrance	Within 100 feet of entrance
On-site Directional Signs - Art. 8.G.3.D		
	Permitted	Provided
Max. No.	N/A	At entrances to Pods; within all Civic Pods; Commercial Pod and Private Recreation
Sign Face	24 SF	Up to 24 SF
Max. Ht.	7 feet	Up to 7 feet
Project ID Sign - Art.8 - Table 8.G.3.E		
	Permitted	Provided
Max. No.	2 per road frontage with PUD access	Min. 6 (2 on 180th Avenue; 2 on 190th Avenue and 2 on 59th Lane North) and 1 at each Private Recreation Pod
Sign Face	24 SF	24 SF
Max. Ht.	6 feet	6 feet
Min. Setback	10 feet	10 feet

PALM BEACH WEST ASSOCIATES I, LLLP
 1600 SAWGRASS CORPORATE PKWY
 SUITE 400
 SUNRISE, FLORIDA 33323
 954-753-1730

Consultants:
CIVIL ENGINEER
 GLH Engineering, LLC
 1600 Sawgrass Corporate Pkwy
 Suite 400
 Sunrise, FL 33323
 954-753-1730
SURVEYOR
 Sand and Hills Survey, Inc.
 8461 Lake Worth Road, Suite 410
 Lake Worth, FL 33467
 (561) 209-6048
TRAFFIC ENGINEER
 Simmons and White
 2581 Metrocentre Blvd. Suite 3
 West Palm Beach, FL 33407
 (561) 478-7848
PLANNERS
 Urban Design Kilday Studios
 610 Clematis Street, Suite CU02
 West Palm Beach, FL 33401
 (561) 366-1100

Project:
INDIAN TRAILS GROVE - PUD

Palm Beach County, Florida
 Sheet title:
PRELIMINARY Master Sign Plan

Date:
2015-07-15

Revisions:
 2015-09-28 Resubmittal

Amendments:

Zoning Stamps:

Sheet number:

PMSP-1